

Princip oskrbovalnega kroga

ALENKA KNEZ
Design Manager

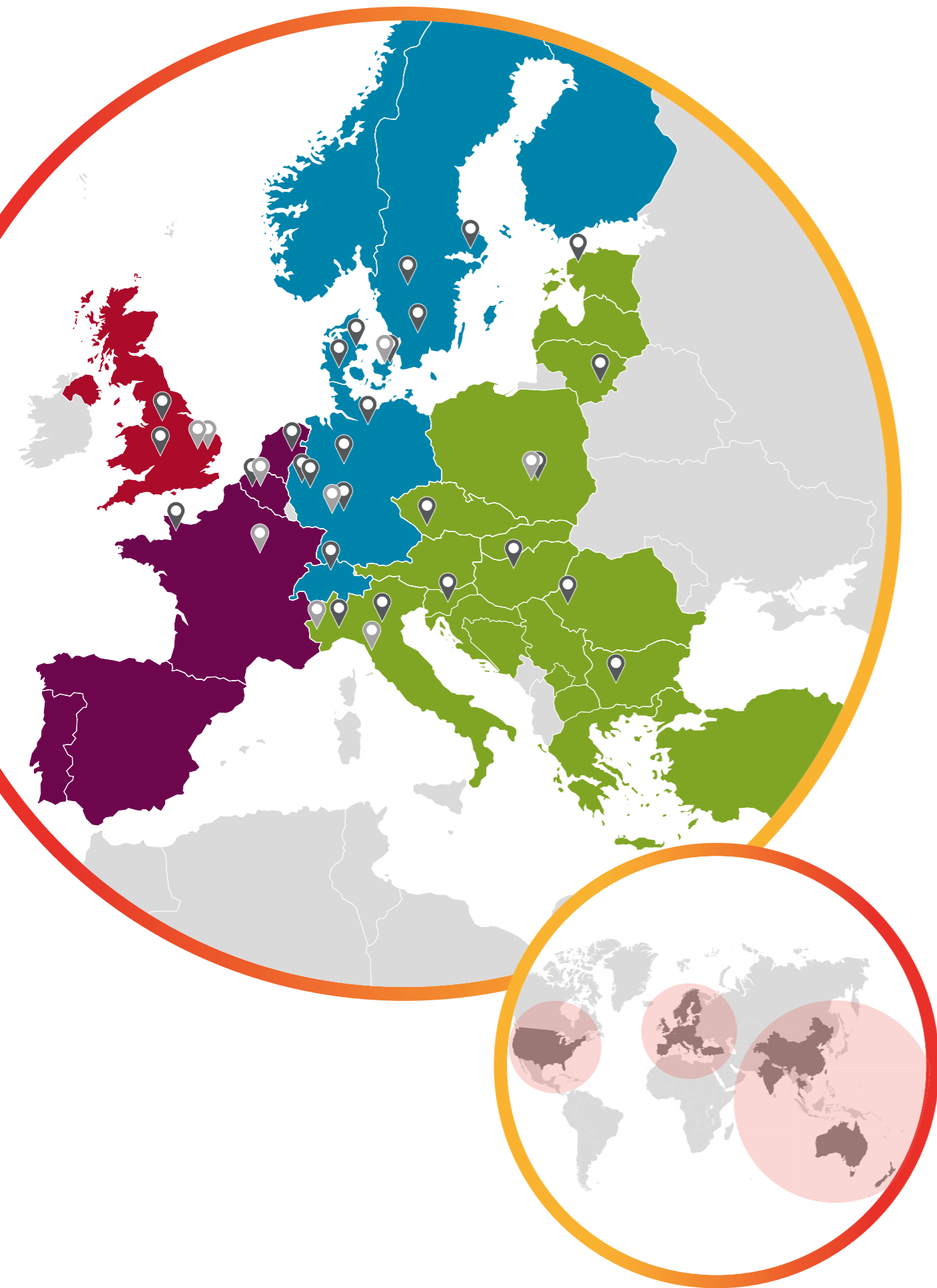



Skupina DS Smith

>>> 26,000 zaposlenih

>>> v 36 državah
OBRATUJEMO PO CELEM SVETU

>>> naše divizije
EMBALAŽA, ODPADNI PAPIR,
PAPIR, PLASTIKA

>>> I. 1940 brata Smith
USTANOVITA PODJETJE V LONDONU

Kje smo



SKUPNO ZAPOSLENIH: 470
REALIZACIJA: 63 MIO EUR
LETNO IZDELAMO BLIZU 120 MIO M²





Naša vizija je biti
vodilni dobavitelj
trajnostnih embalažnih
rešitev

DS Smith
PackRight
Centre



Na ustvarjalnih delavnicah skupaj z vami prenesemo idejne osnutke, iz lista papirja, na predelovalne stroje.



Dobra embalažna rešitev je
kreirana po vaši meri.



**Povečanje
prodaje**



**Zmanjšanje
stroškov**



**Zmanjšanje
tveganj**

Orodja in strokovno znanje

Pack Right

...je naš način dela,
kreiranje rezultatov in prihrankov...



Vhodni material



Proizvodnja



Skladiščenje i
Malo prodaja distribucijski
transport



center



Trgovina



Kupec



Reciklaža

Prilagojena orodja in programska oprema

>>>  Naša PackRight kreativna orodja



Imamo jasen vpogled v vse faze dobavne verige



in generiramo rešitve, ki prinašajo rezultate



More Sales



Lower Cost



Risk Managed

DS Smith Value Tool

>>> Ustvarjene rezultate in prihranke lahko dokažemo...

Cost comparison

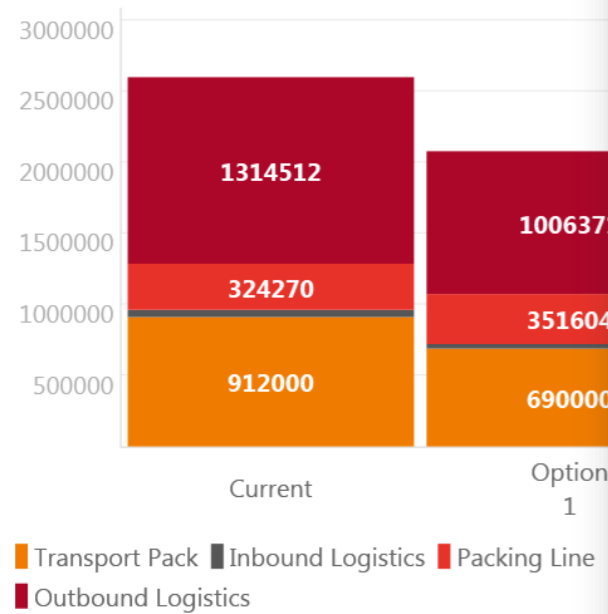

Detailed proposals and anticipated results.

8

Cost Comparison

Current: 881,600 €
Option 1: 518,525 €



Total Saving: € 363,072



Optimizacija štirih faz kupčevega dobavnega kroga

Projekt – poslovna priložnost

Plato za transport zmrznjenega mesa
Project: Optimizacija izvedbe, porabe materiala, vhodne logistike in časa pakiranja

Lokacija in kontakt

DS Smith - Brestanica
država - Slovenija

Smernice za izboljšave



- Pocenitev embalaže

Opis rešitve



Optimizacija izvedbe:
Plato je strojno lepljen,
Poraba materiala je manjša za 20%,
Zložaj je na paleti stabilen.

Optimizacija materiala:
Redukcija gramature
iz 654 g/m² na 641 g/m².

Optimizacija paletizacije:
Dva zložaja na paleti

Optimizacija časa pakiranja
Sestavljanje platojev je sedaj strojno

Vizualizacija

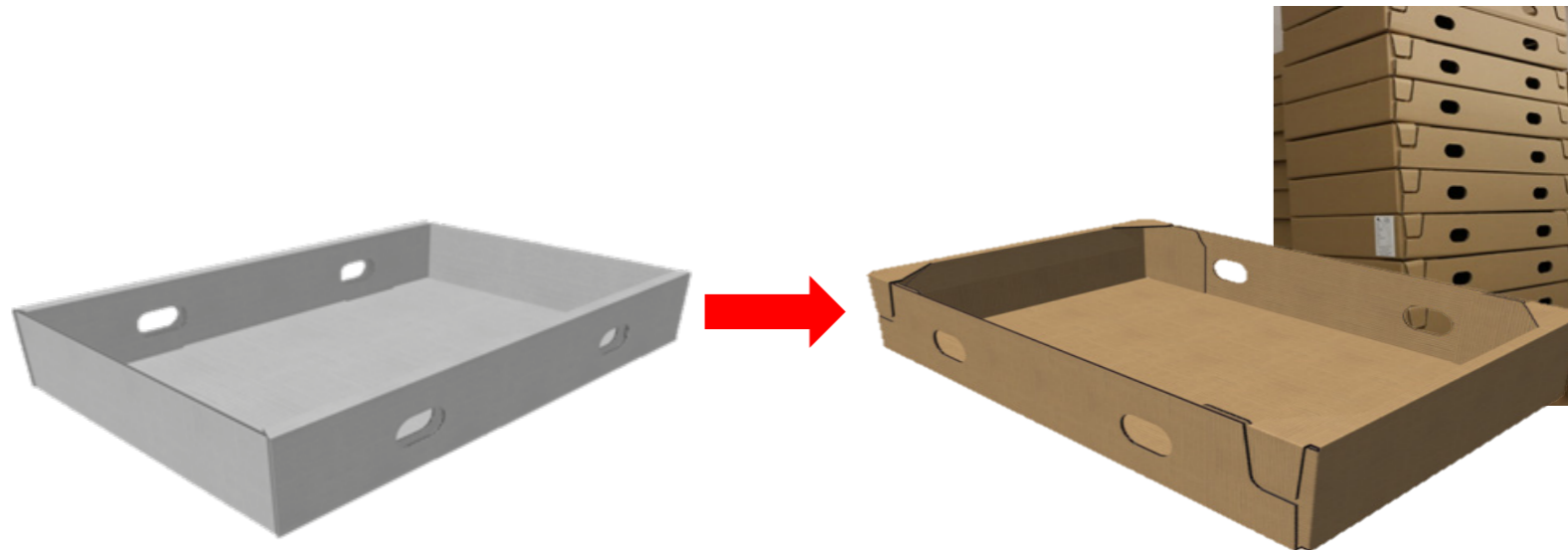

Managed risk



Lower Cost



Increased Sales

Uspešna zgodba DS Smith - trajnostni vidik

4 m² prostega paletnega prostora



161 manj palet



12 kamionov manj na cesti



43% manj CO₂ emisij



20% manj materiala



Primer dobre prakse razvoja projekta

i-PACK

EMBALAŽA
ZA SPLETNO PRODAJO

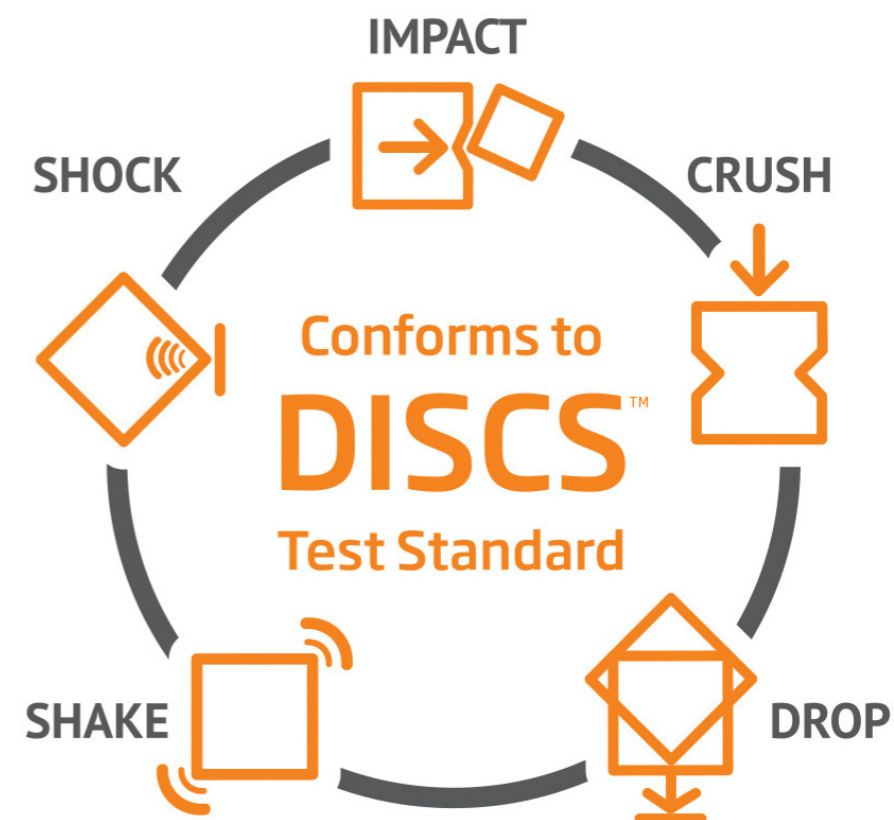

AJDA REGALI KNEZ
DS Smith Graduate Scheme

»»» **1.23 bilijonov**
UPORABNIKOV TABLIČNIH RAČUNALNIKOV V L. 2017

»»» **42.5 milijonov**
POŠLIJK TABLIČNIH RAČUNALNIKOV ZNAMKE APPLE V LETU 2016

»»» **elektronika 46%**
VSEH ONLINE NAROČIL

»»» **socialna omrežja**
INSPIRACIJA ZA SPLETNI NAKUP

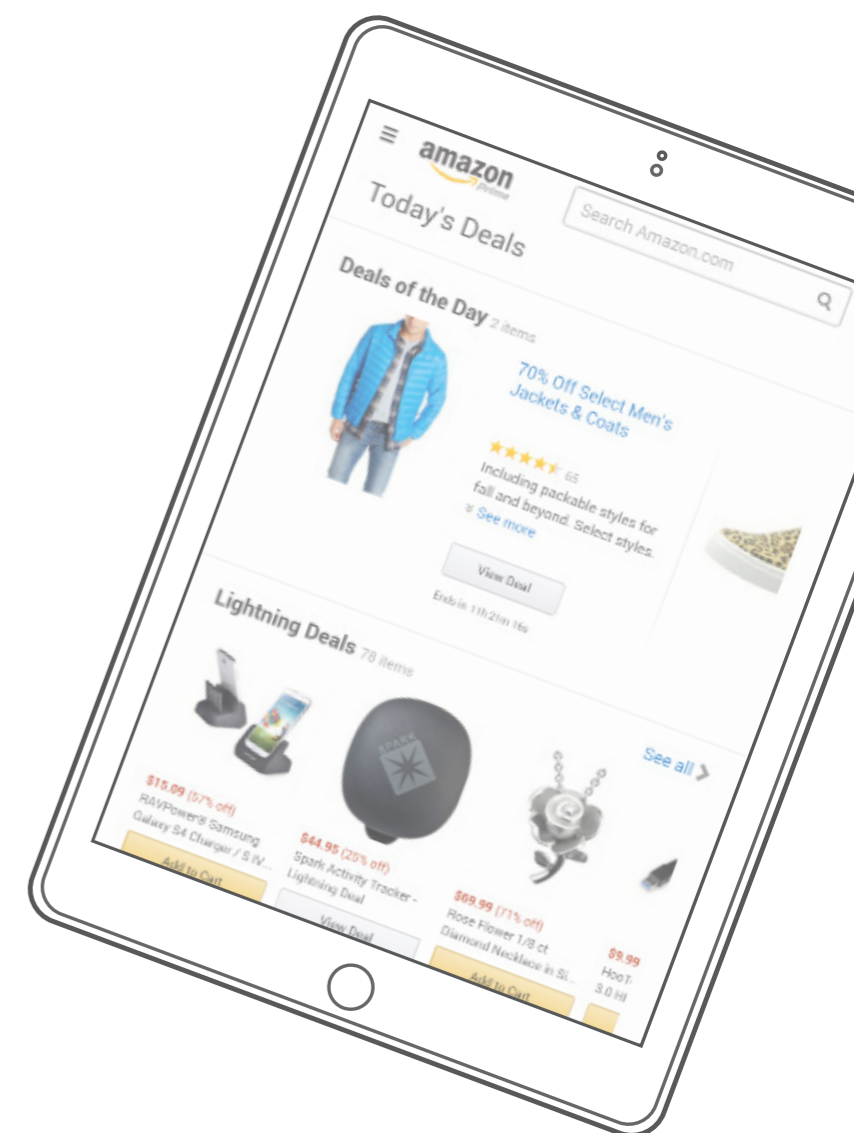

odkrij!
tablični rač. in e-trgovina

raziskava

embalaža za spletno prodajo

>>> prilagojen dizajn / prilagojen tisk
73 % bolj pomemben

>>> vračilo izdelkov v prvotni embalaži
78 % (večina anketirancev preferira)

>>> embalaža naj reflektira okoljske vrednote
77 % (večina anketirancev preferira)

>>> pošiljanje brez dodatnih pakiranj
2/3 potrošnikov preferira



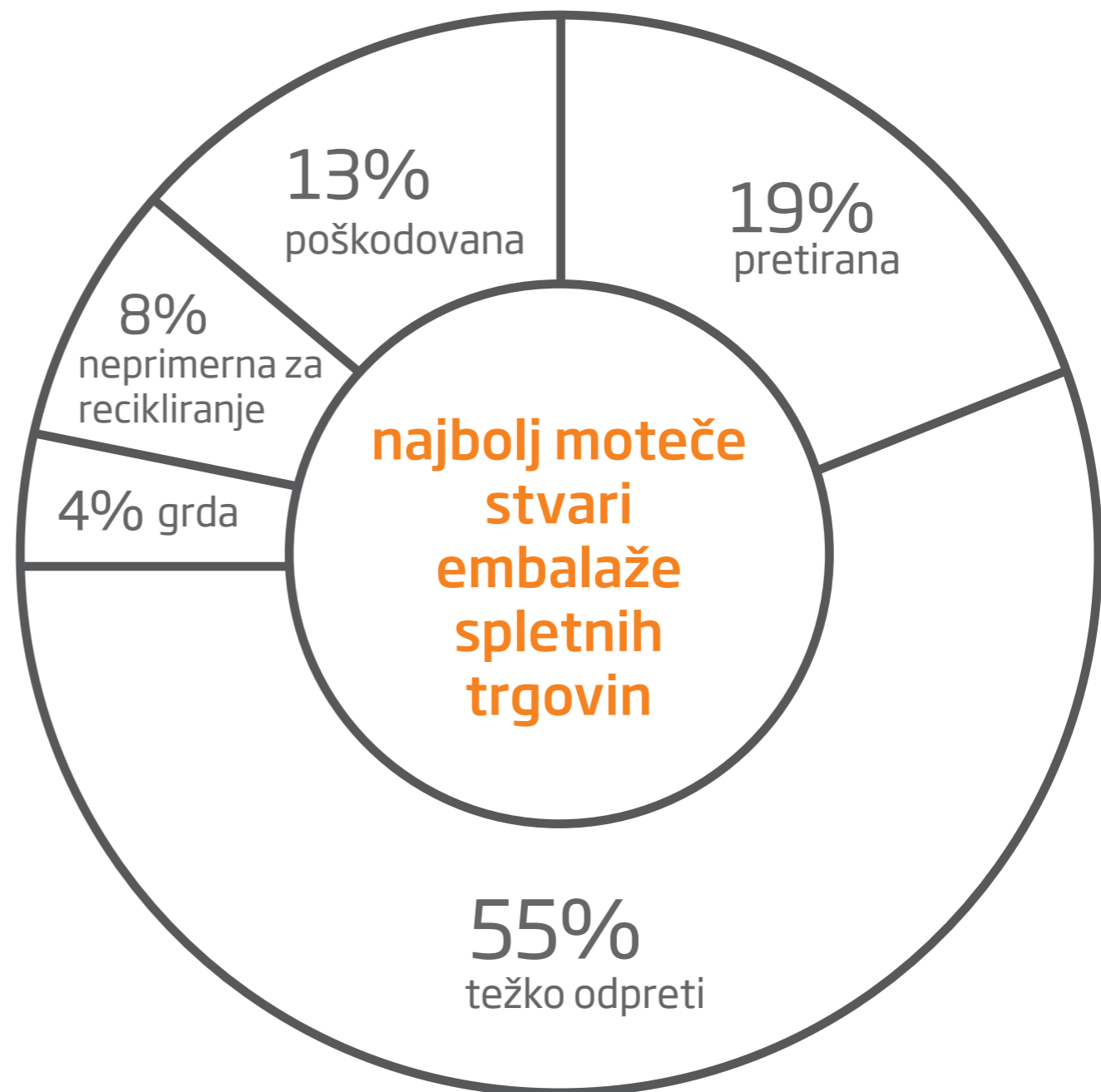

>>> samo **11%**
anketirancev zadovoljnih z embalažo, ki so jo dobili

>>> maloprodaja - socialna izkušnja



Donating is as easy

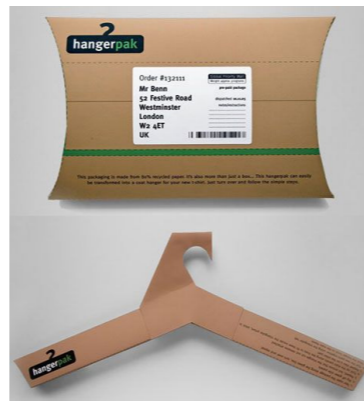

>>> okolju prijazne rešitve

>>> embalaža za večkratno uporabo

>>> iPad, Samsung tablični računalniki dodatno zunanje pakiranje / Amazon Kindle: easy to open embalaža

trenutna situacija na trgu

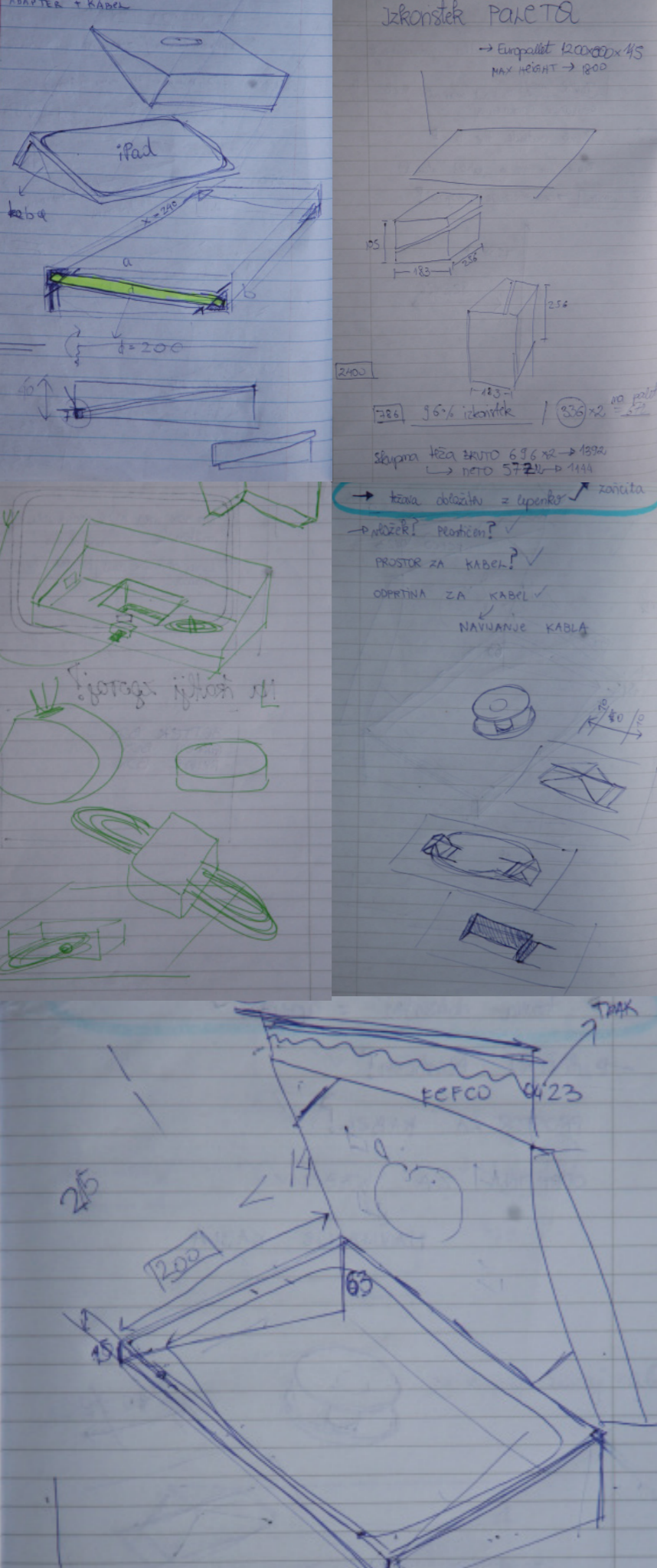

definiramo izhodišča in cilje



- ENOSTAVNO ODPIRANJE
- OKOLJU PRIJAZNO
- ENOSTAVNO RECIKLIRANJE IN PONOVA UPORABA
- BREZ DODATNEGA ZUNANJEGA PAKIRANJA
- PRAVILNA VELIKOST ŠKATLE
- VARNA EMBALAŽA
- BLAGOVNA ZNAMKA
- WOW! - PREDSTAVITEV IZDELKOV
- ZUNANJOST BREZ TISKA - ZMANJŠATI MOŽNOST NEDOVOLJENE UPORABE ALI KRAJE MED LOGISTIČNO VERIGO
- DOBRA IZKUŠNJA KUPCA
- PRIHRANEK PRI DISTRIBUCIJI - OPTIMALNA PALETIZACIJA

razvoj testiranje, prototipiranje

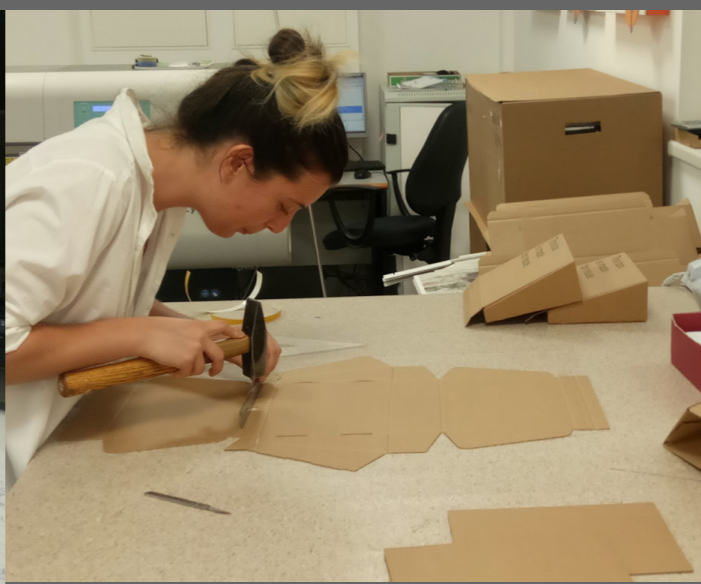

i-pack



proces zlaganja
ENOVIT PLAŠČ VALOVITEGA KARTONA



ponovna uporaba
KOT STOJALO ZA TABLIČNI RAČUNALNIK /
ENOSTAVNO VRAČILO V PRVOTNI EMBALAŽI

>>> europaleta - 672 kosov
1200mm x 800mm x 2000mm (max višina)

>>> teža
EMBALAŽA BRUTO: 1,392 kg
NETO: 1,144 kg
TOVOR: 492,7120 kg

>>> izkoristek prostornine:
92,8 %

>>> izkoriščenost površine palete:
96,1 %

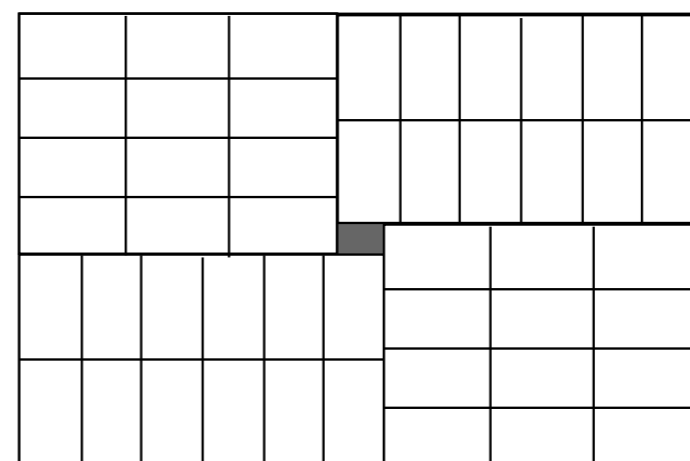
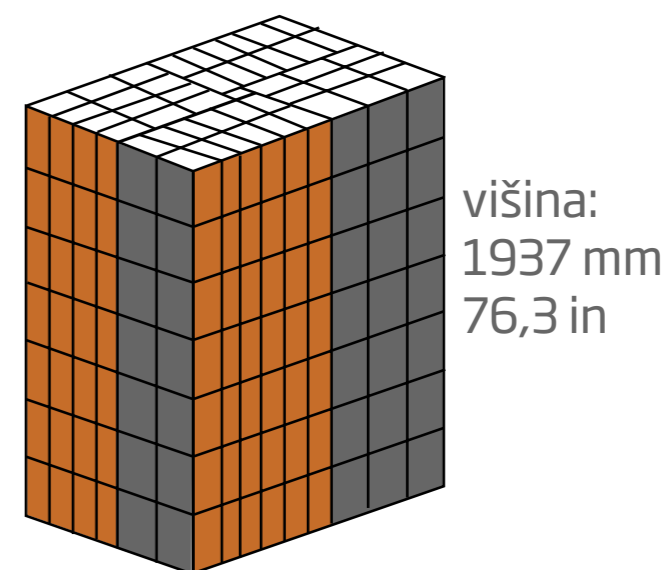
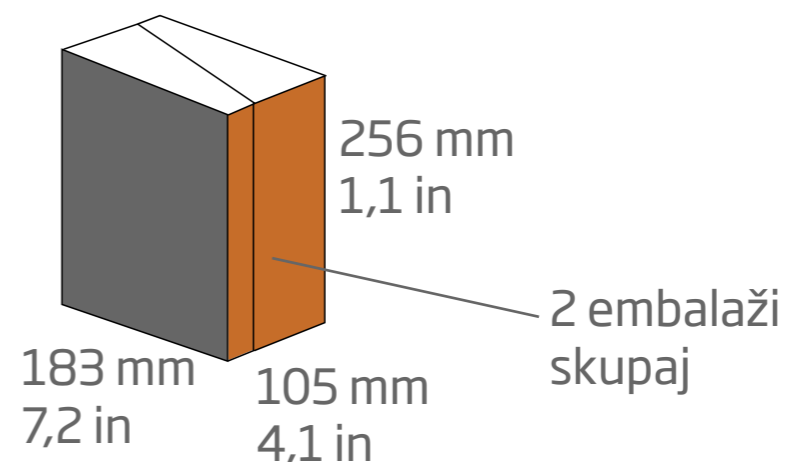

**optimalna
paletizacija**

več o embalaži i-pack

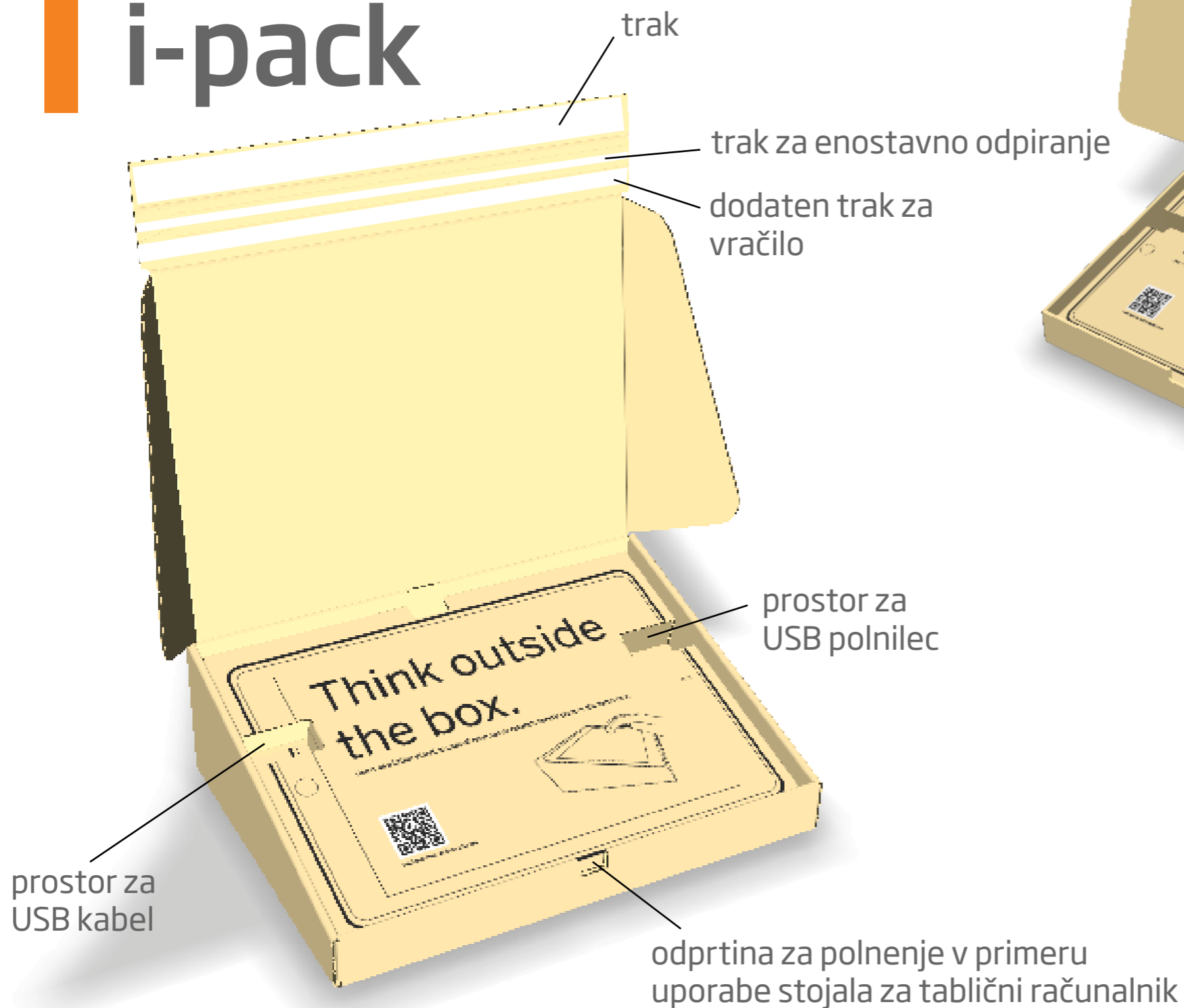





United
colleagues



Smart
thinkers



Industry
leaders