

ANDRITZ

Pulp & Paper

New technologies for drying sections

Comparison of different concepts

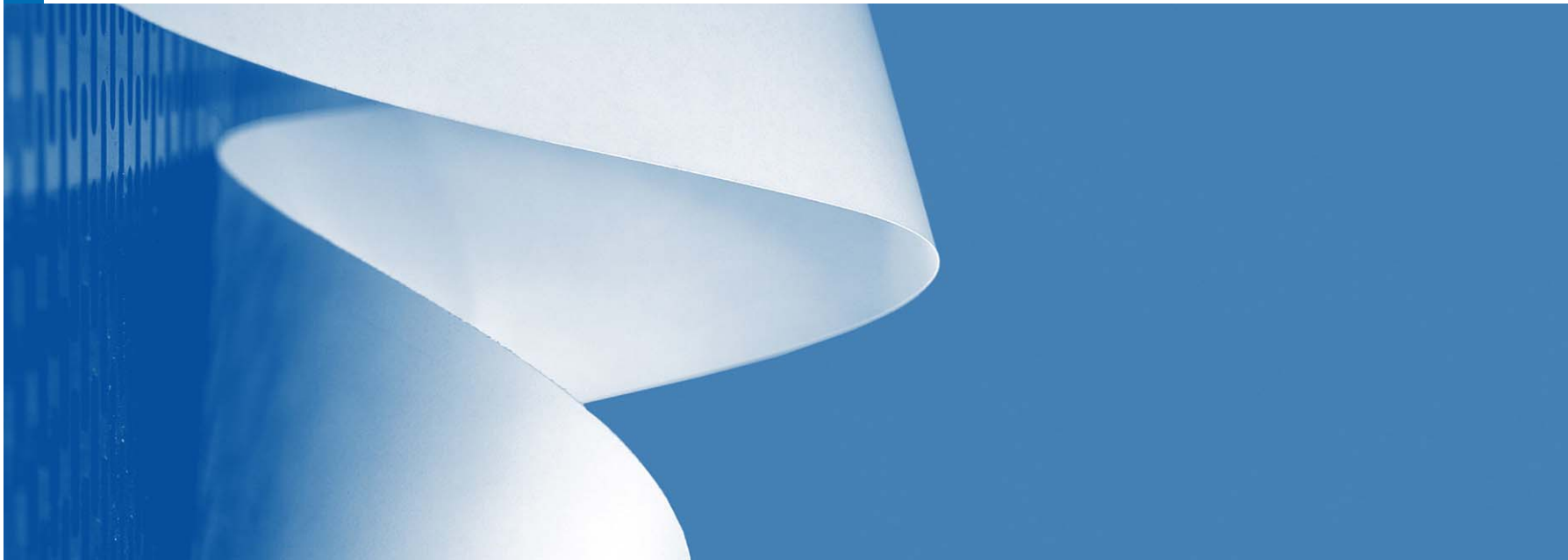

New technologies for drying sections

Contents

- Case study contact drying
 - Cast cylinder
 - Steel cylinder
 - High temperature cylinder
- Case study impingement drying
 - Indirect
 - Direct
 - Double sided
- Summary

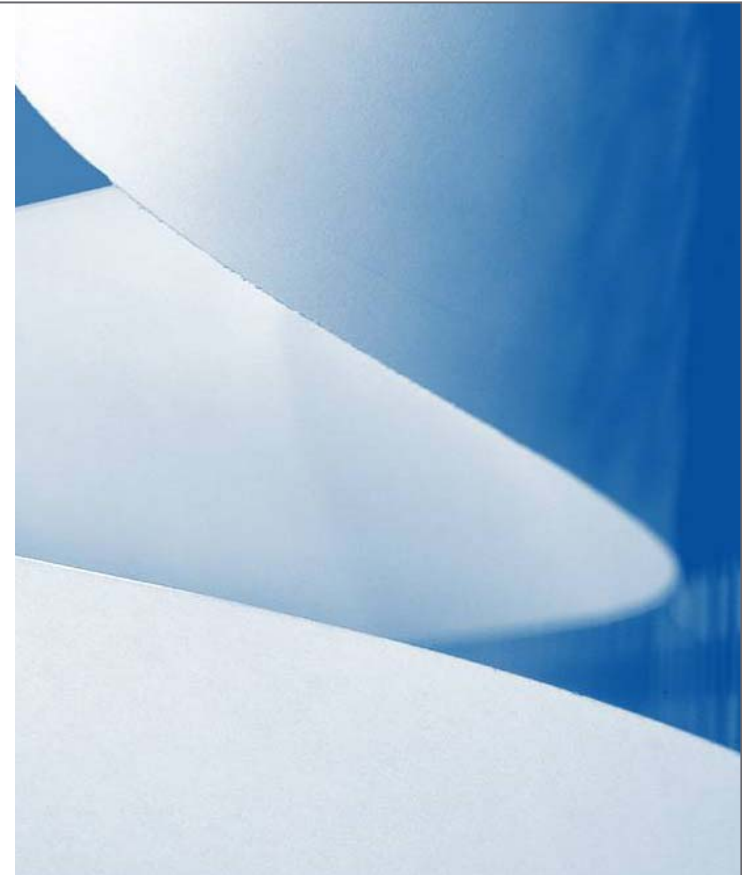

Drying section

Layout for case studies

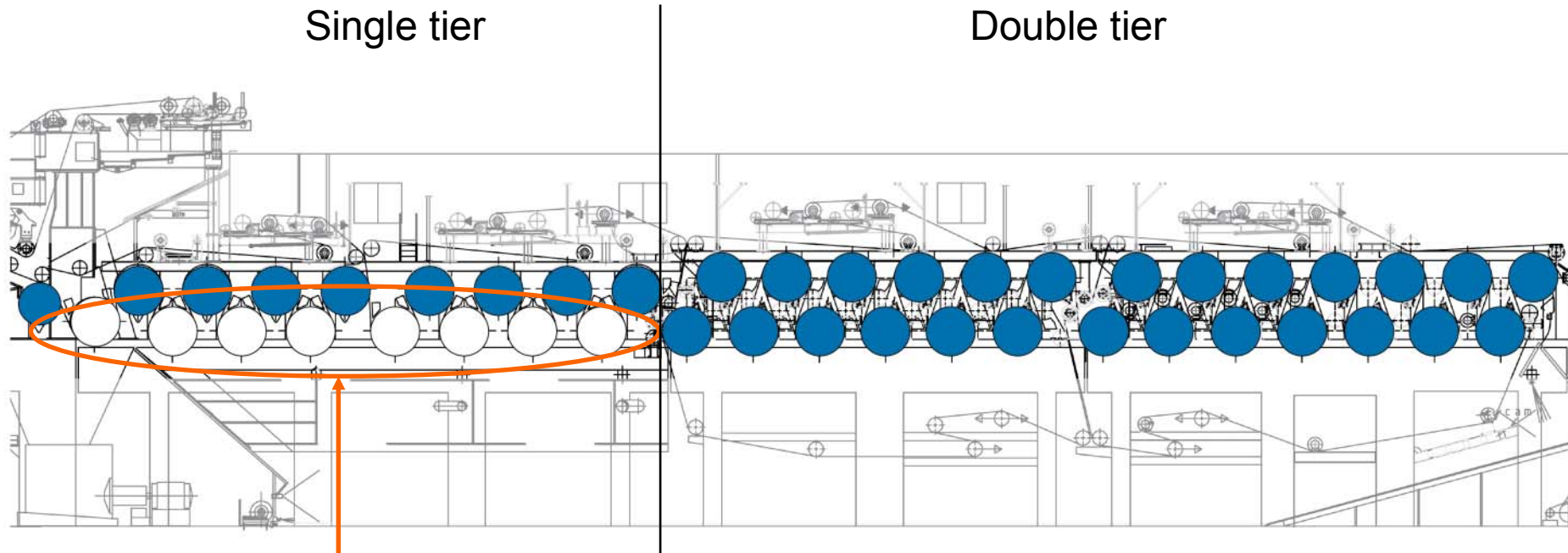

Basis weight:	36 g/m ²
Machine speed:	1600 m/min
after Press:	43 %

New technologies for drying sections

- Case study contact drying
 - Cast cylinder
 - Steel cylinder
 - High temperature cylinder
- Case study impingement drying
 - Indirect
 - Direct
 - Double sided
- Summary

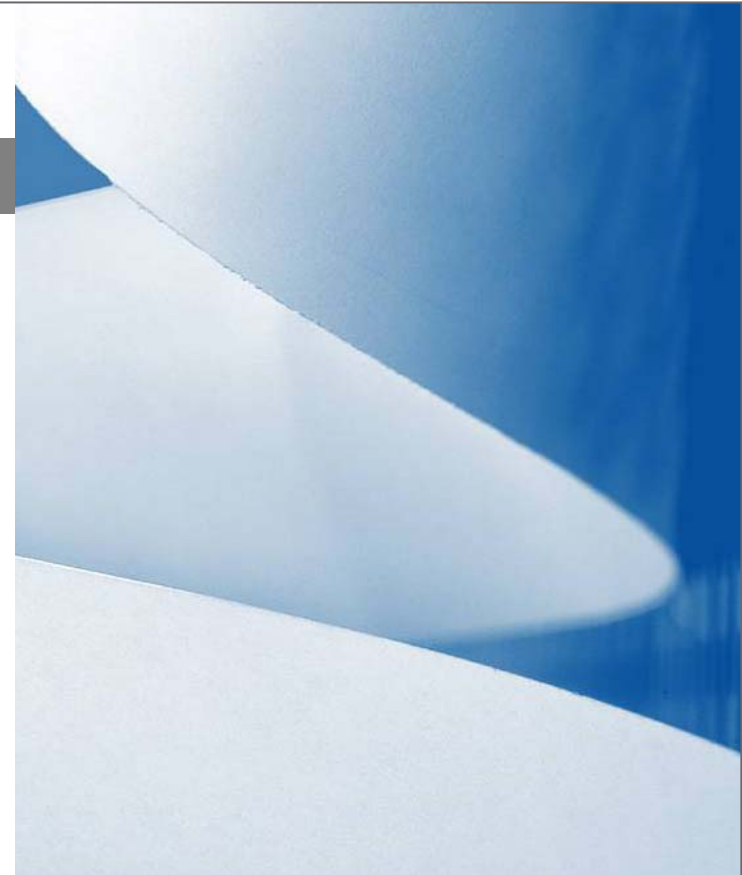

Cast cylinder

Simulation result

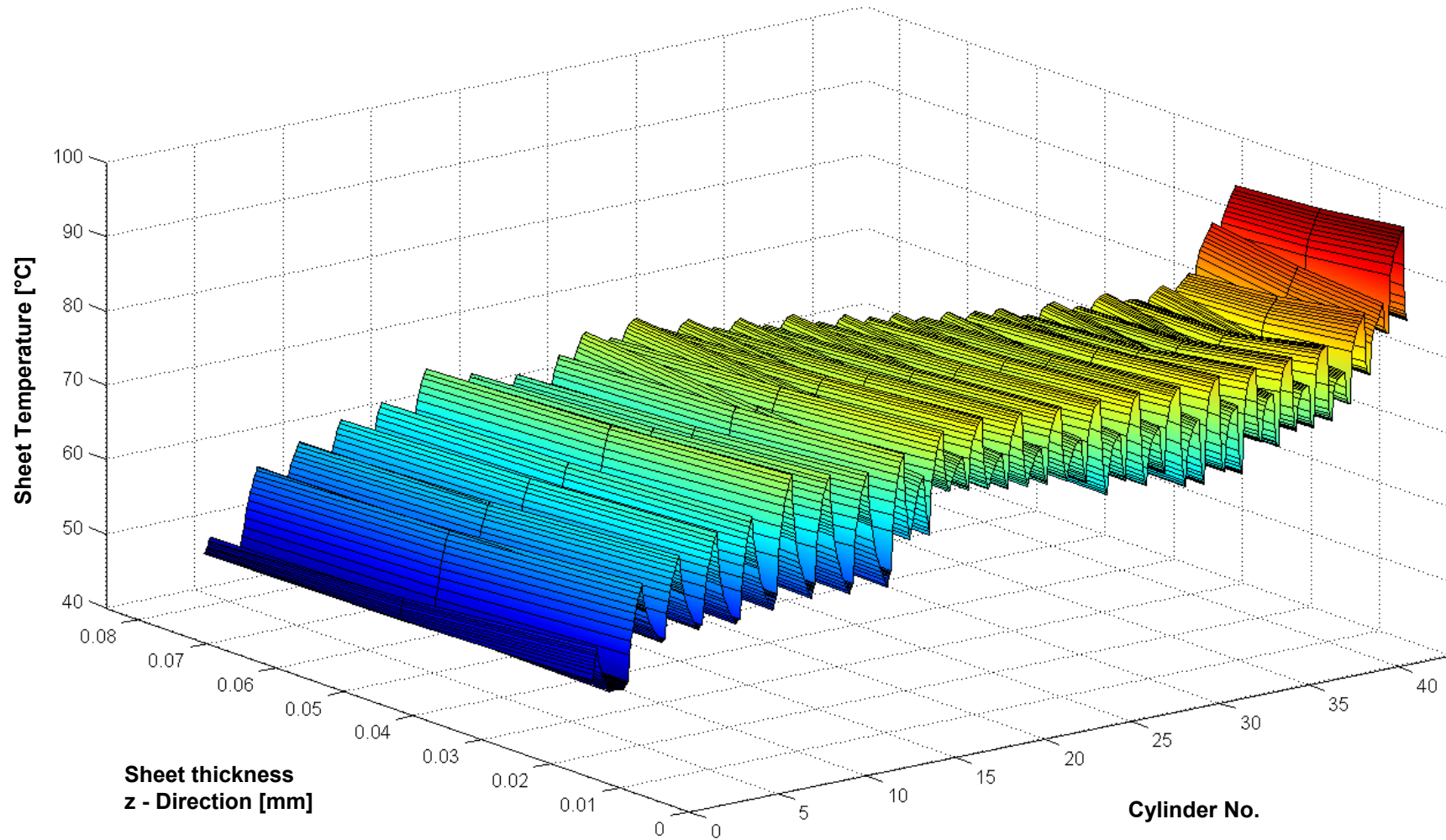

New technologies for drying sections

- Case study contact drying
 - Cast cylinder
 - Steel cylinder
 - High temperature cylinder
- Case study impingement drying
 - Indirect
 - Direct
 - Double sided
- Summary

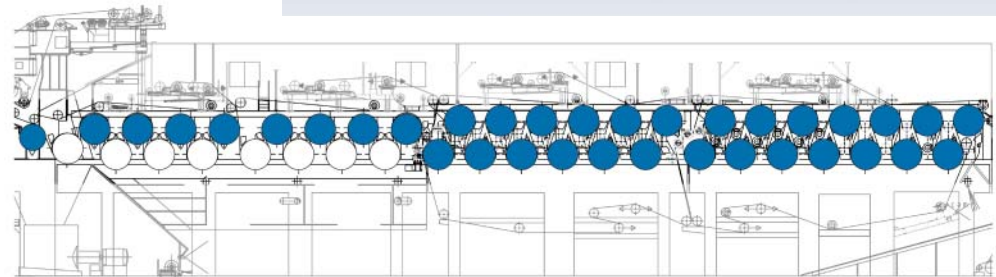
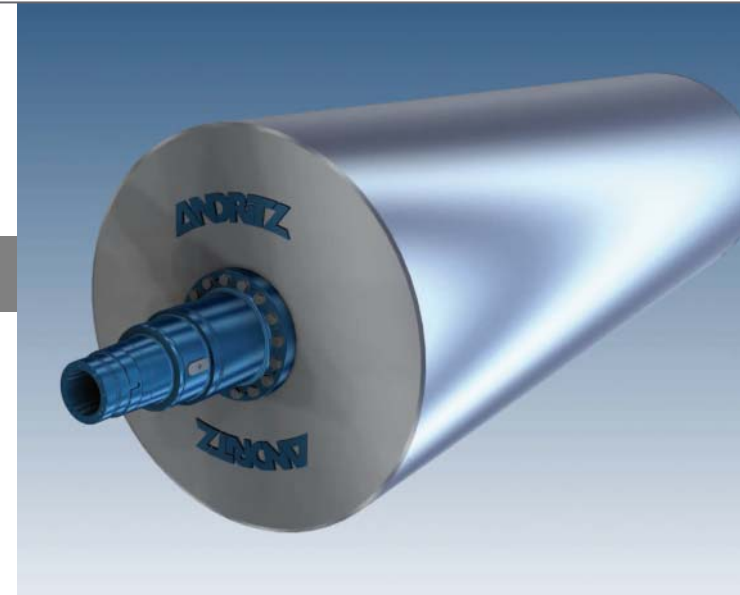

Steel cylinder

Comparison sheet temperature vs. sheet dryness

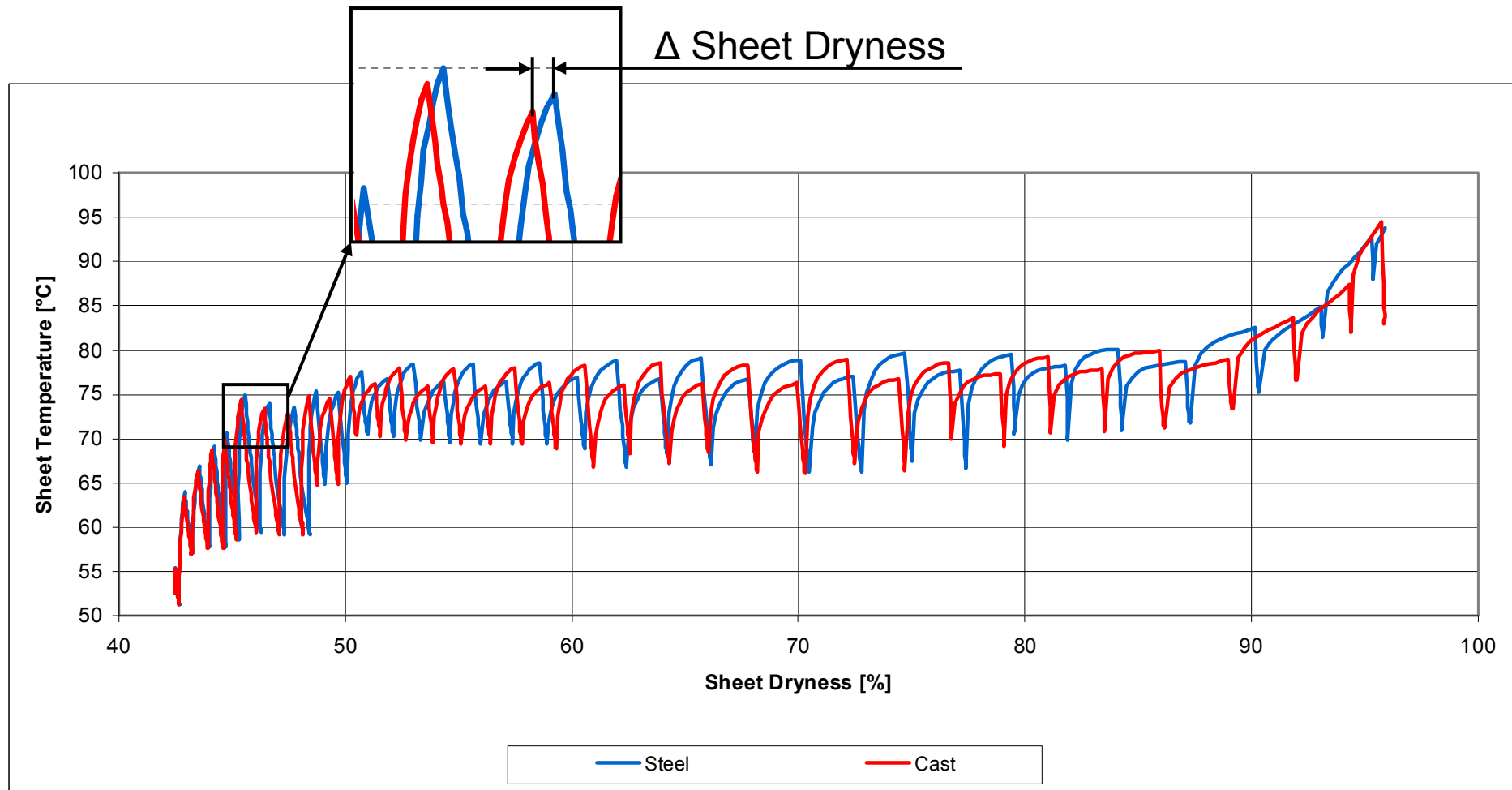

Steel cylinder

Comparison of drying rates from simulation

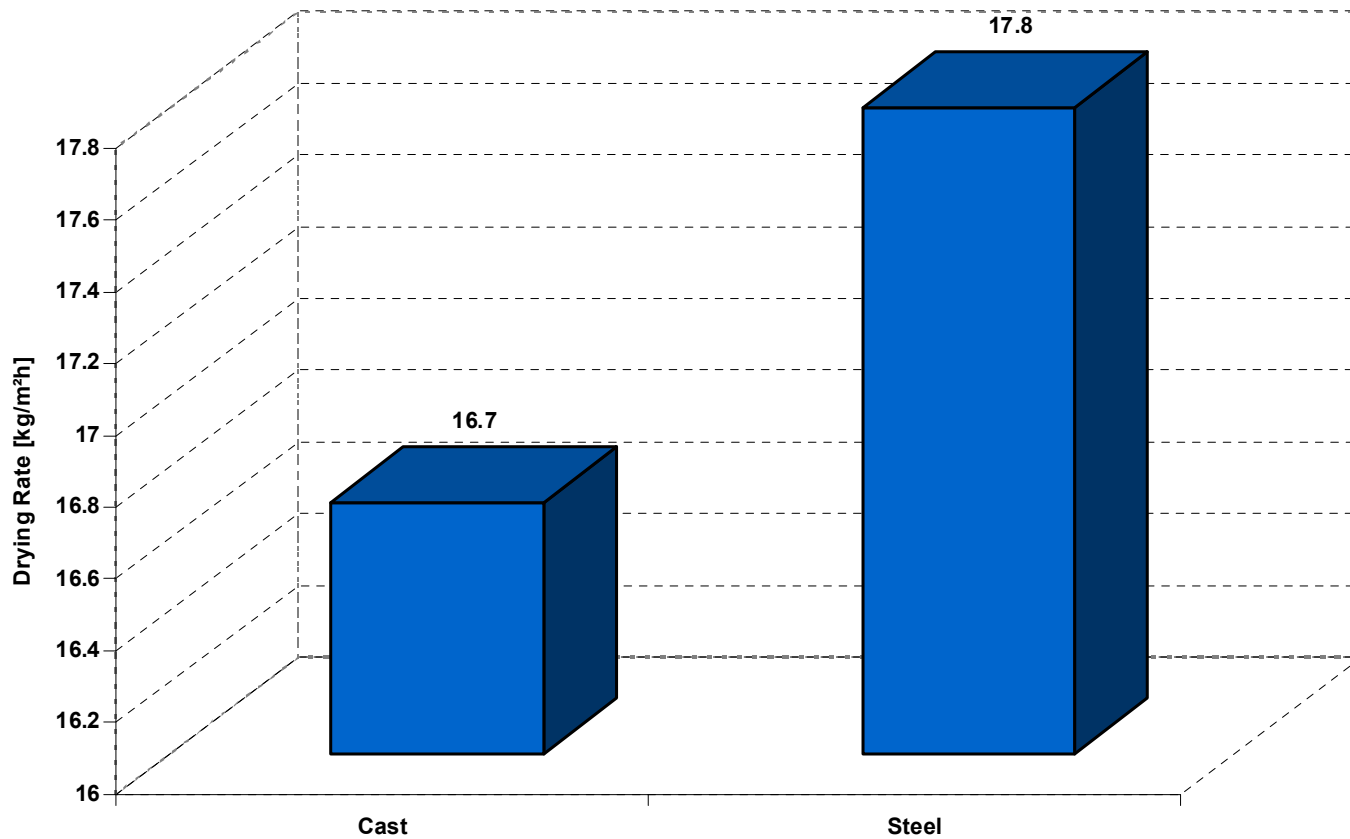

- Reference for steel cylinder rebuild: German board mill, installed in 07/2011

New technologies for drying sections

- Case study contact drying
 - Cast cylinder
 - Steel cylinder
 - High temperature cylinder
- Case study impingement drying
 - Indirect
 - Direct
 - Double sided
- Summary

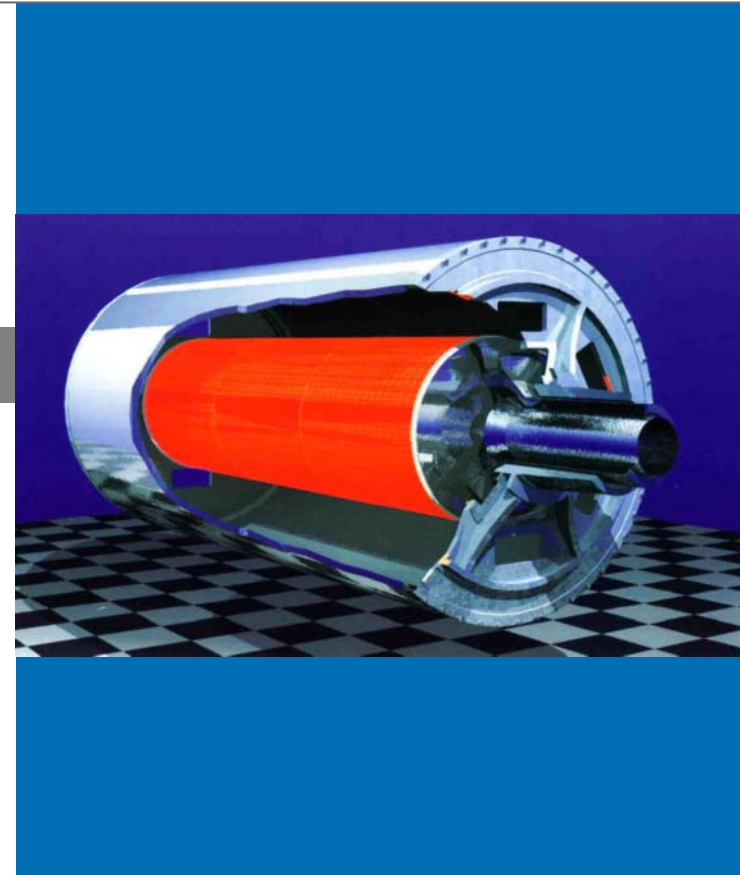

High temperature cylinder

Test arrangement

Labor arrangement

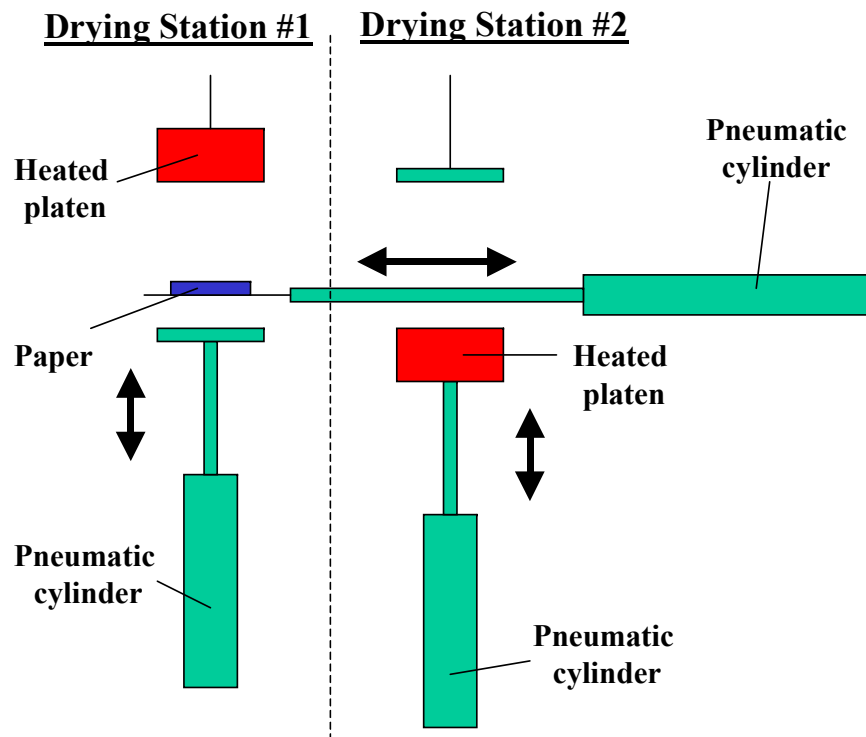

Pilot plant

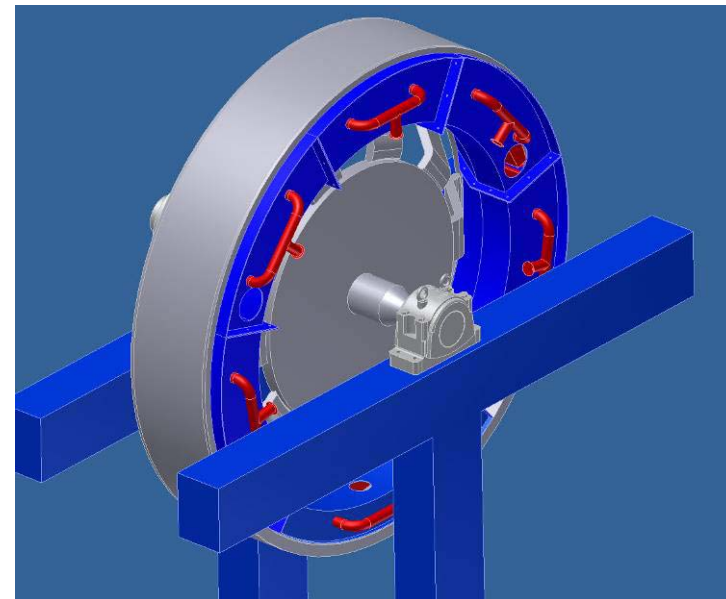

High temperature cylinder

Results drying rates form tests

Labor arrangement

Pilot plant

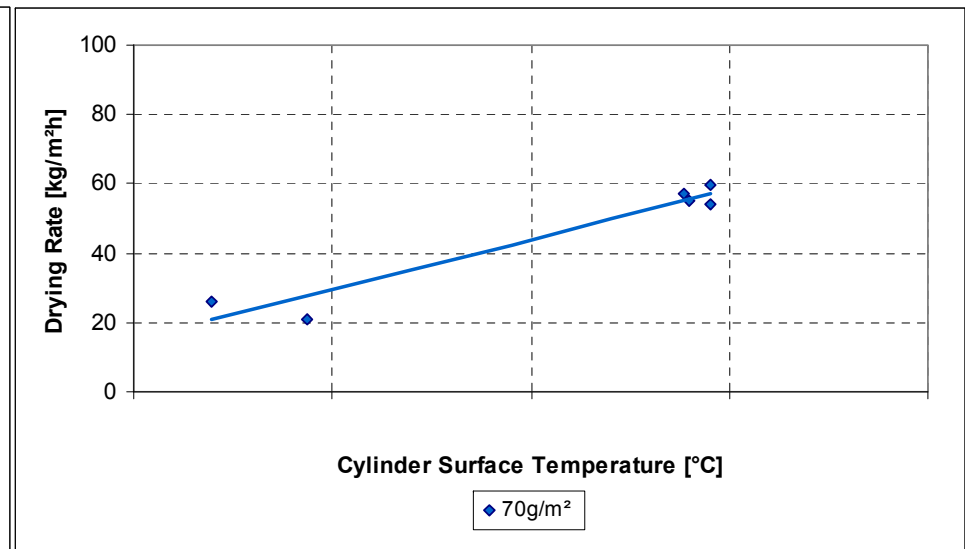
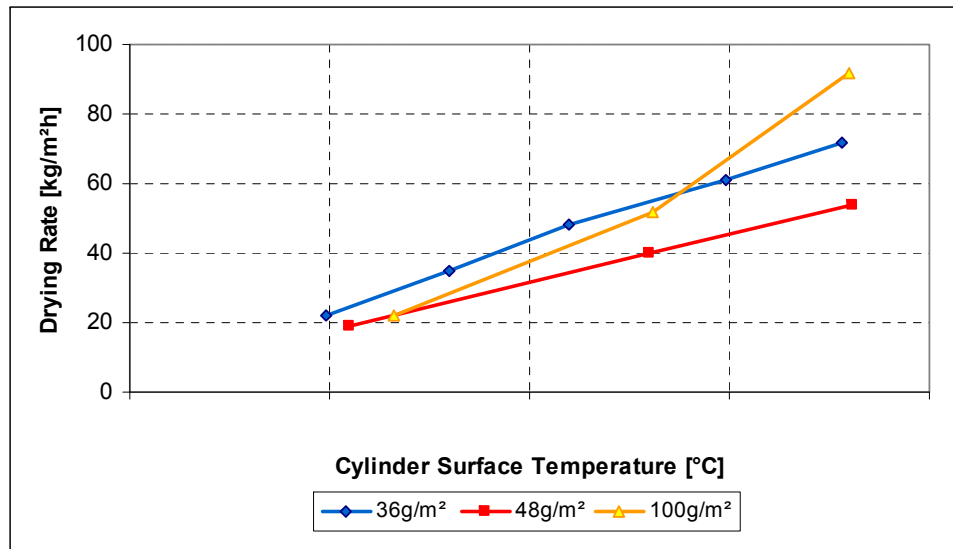

High temperature cylinder

Layout drying section for simulation

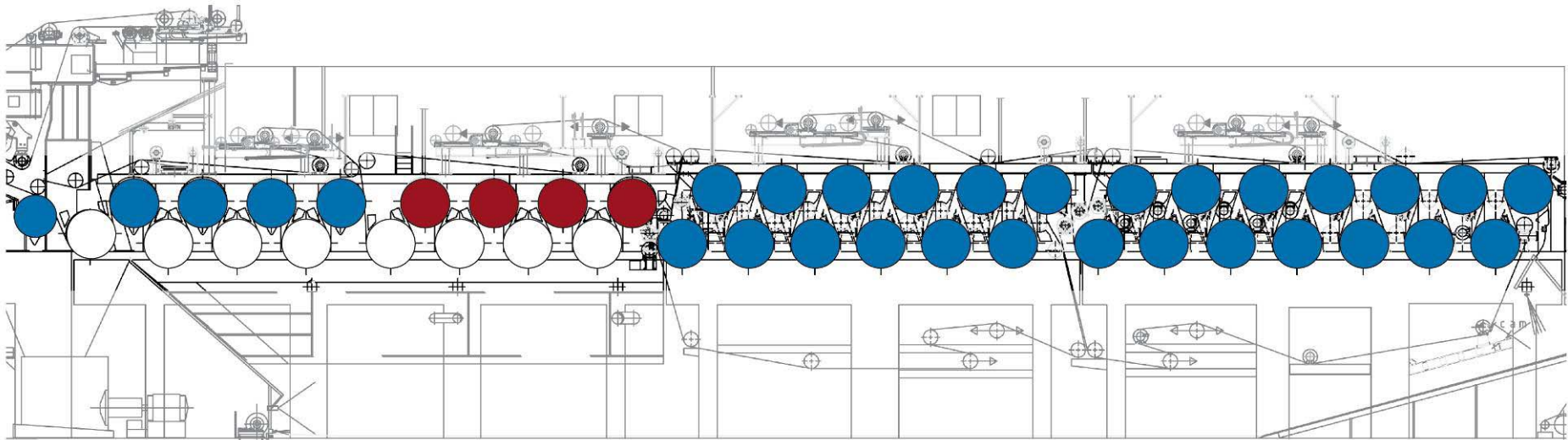

High temperature cylinder

Comparison sheet temperature vs. sheet dryness

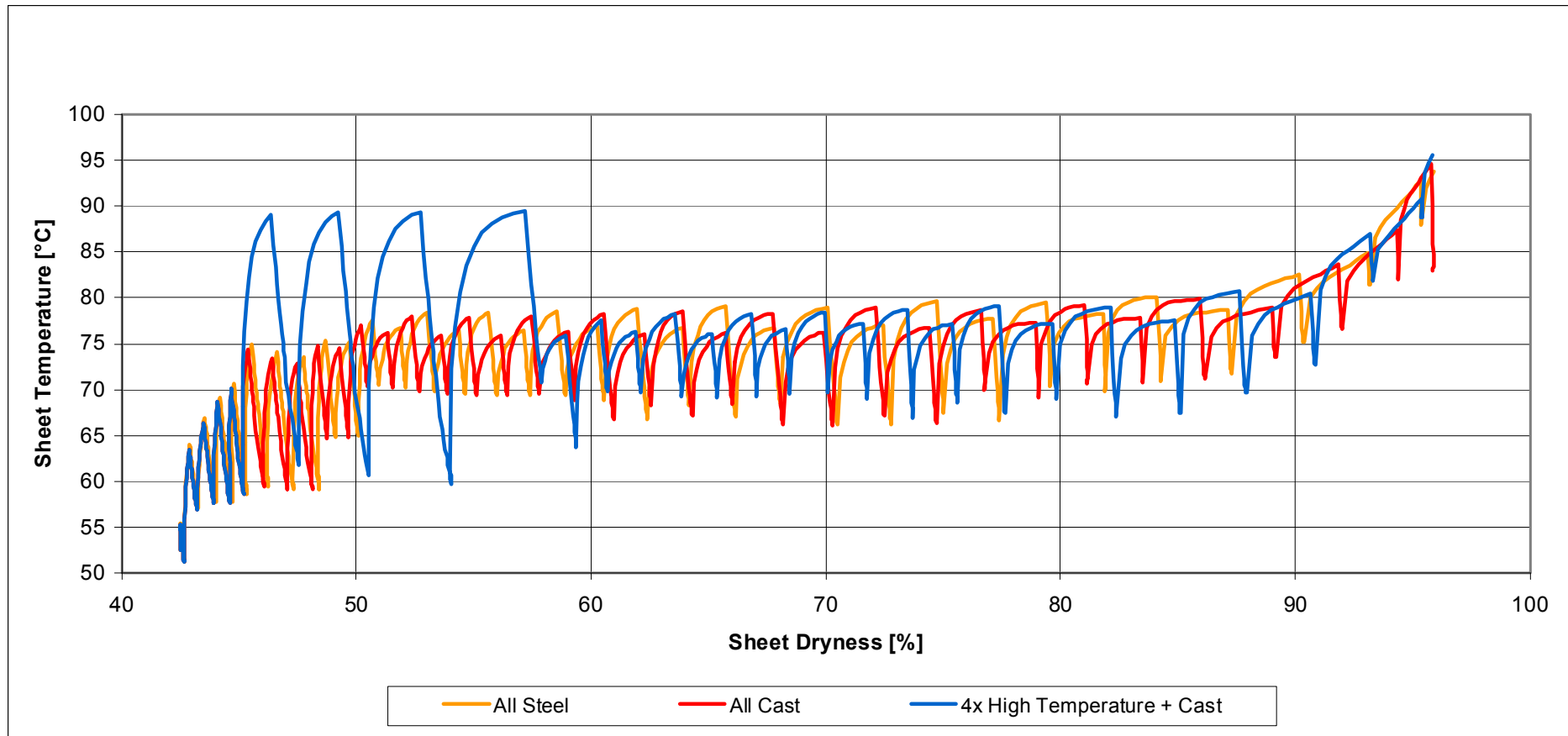

High temperature cylinder

Comparison sheet dryness

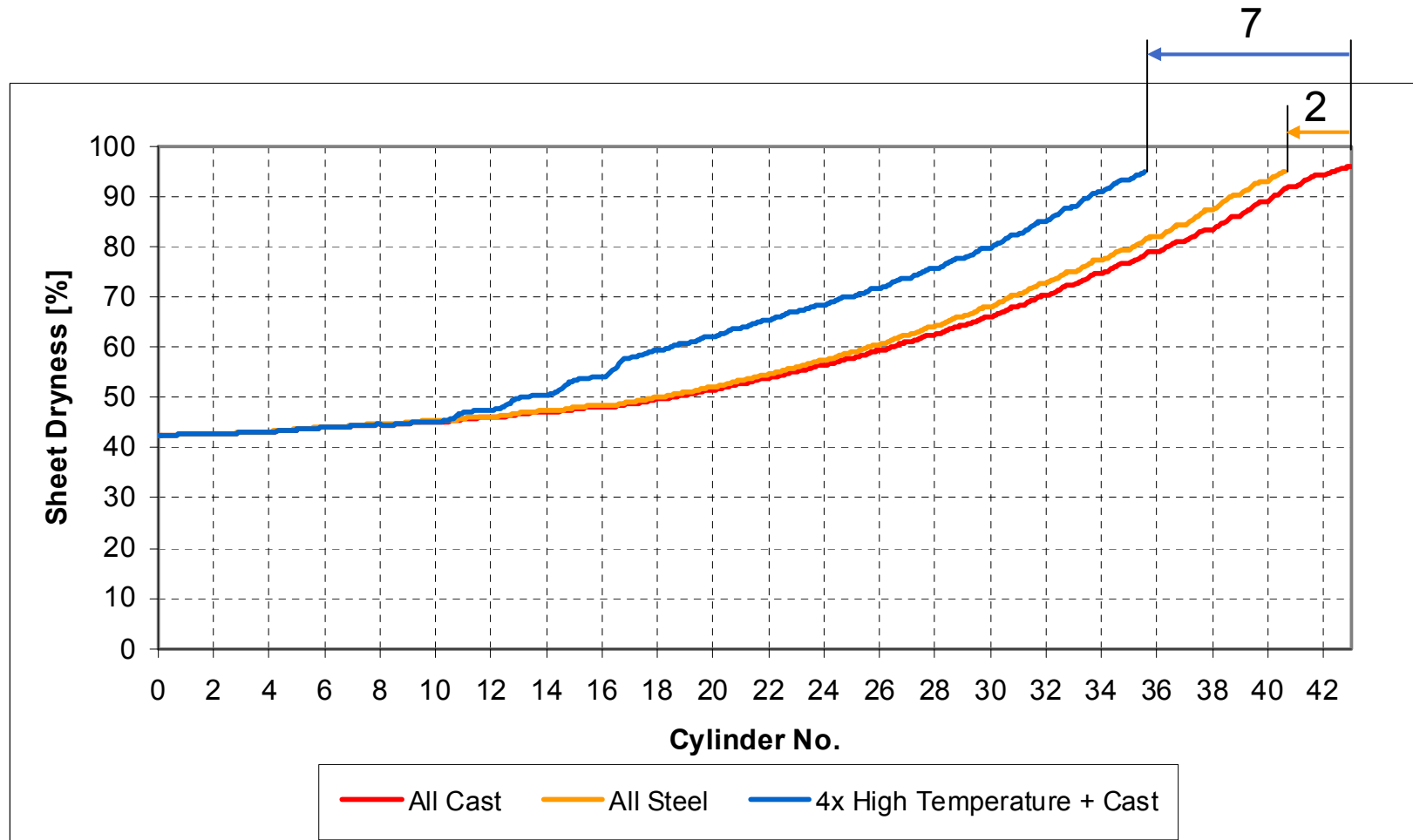

High temperature cylinder

Comparison drying rates from simulation

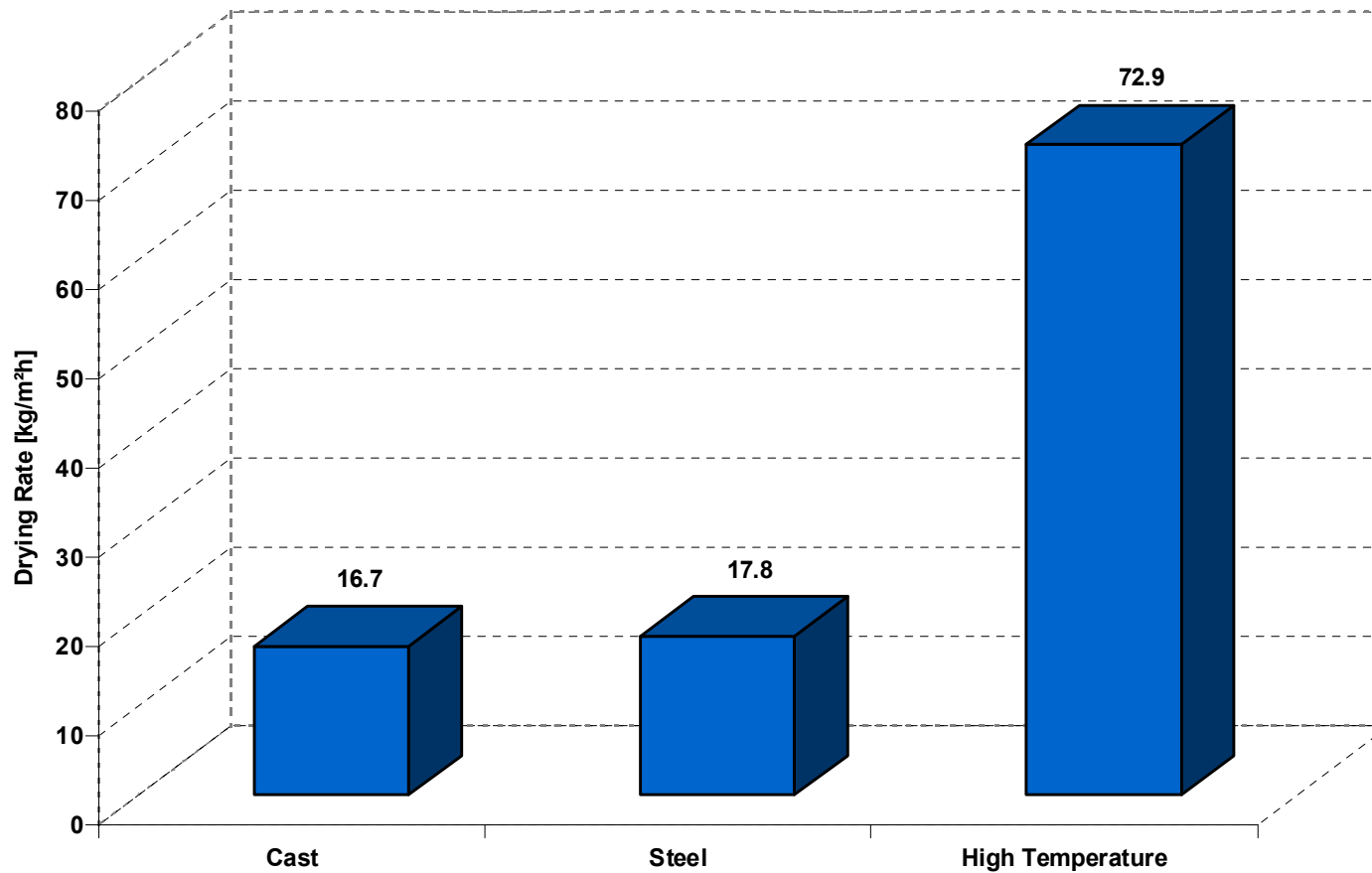

- Reference: PM2, Corrugated Services Inc., Forney, Texas

New technologies for drying sections

- Case study contact drying
 - Cast cylinder
 - Steel cylinder
 - High temperature cylinder
- Case study impingement drying
 - Indirect
 - Direct
 - Double sided
- Summary

Indirect Impingement

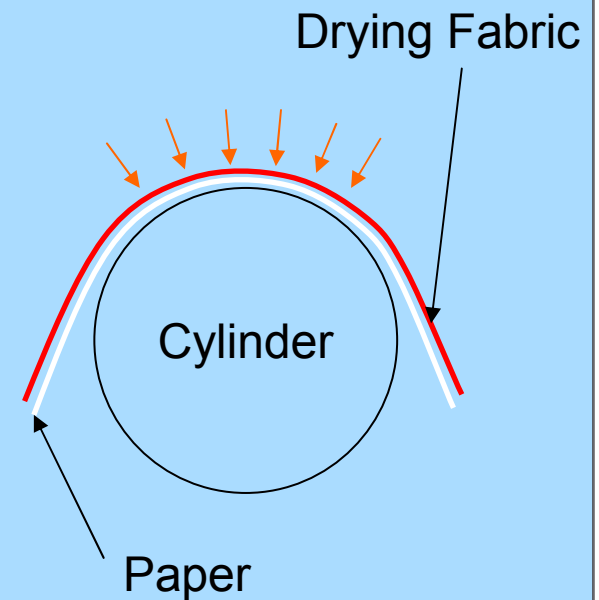

Impingement indirect

Layout drying section for simulation

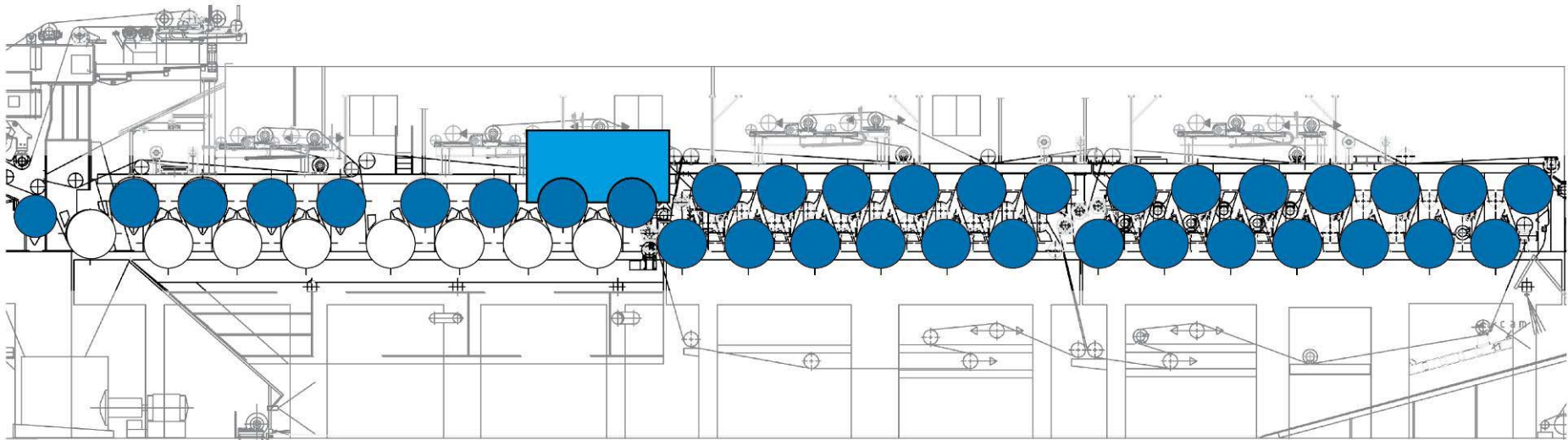

Impingement indirect

Comparison sheet temperature vs. sheet dryness

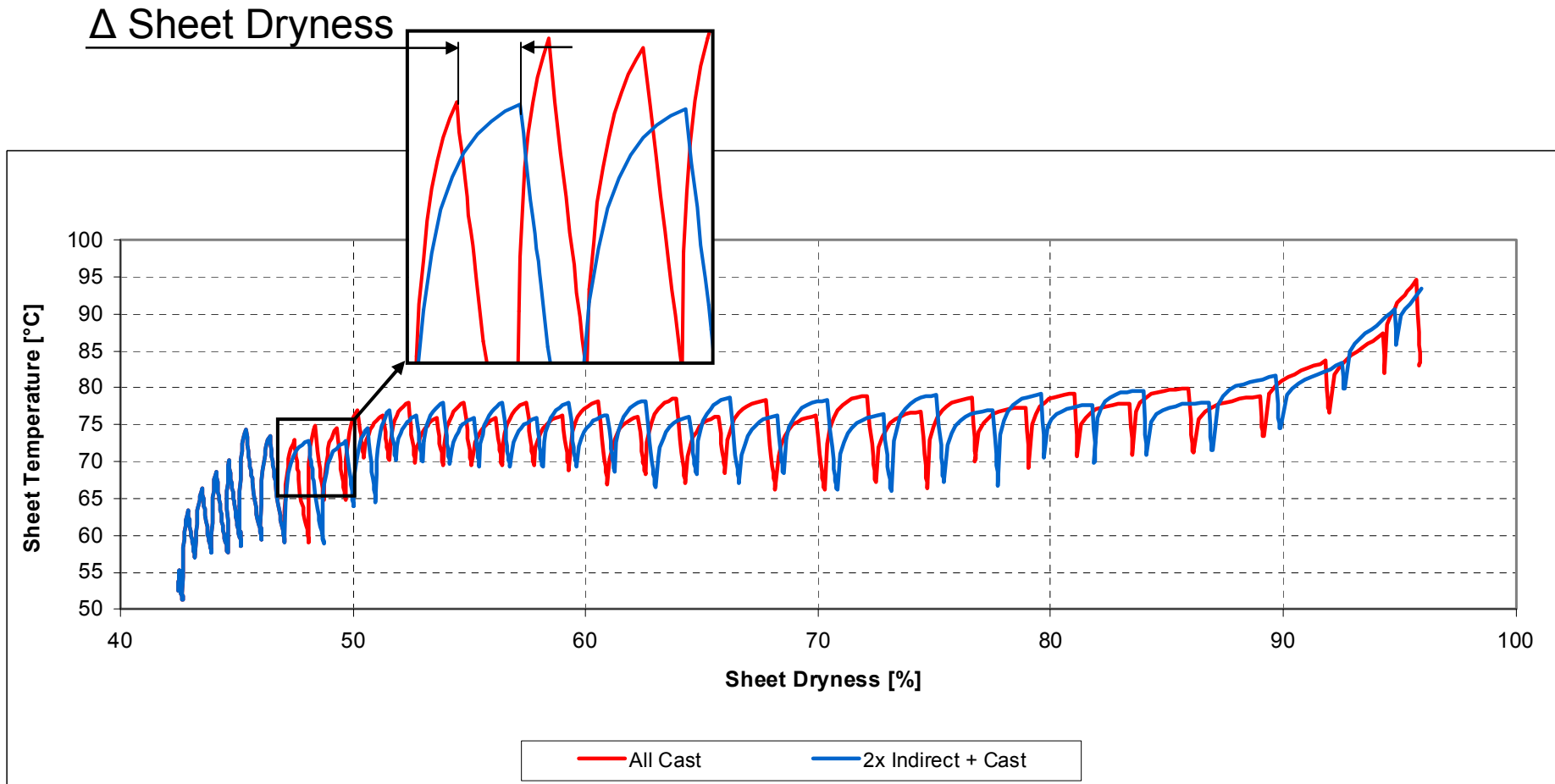

Impingement indirect

Comparison drying rates from simulation

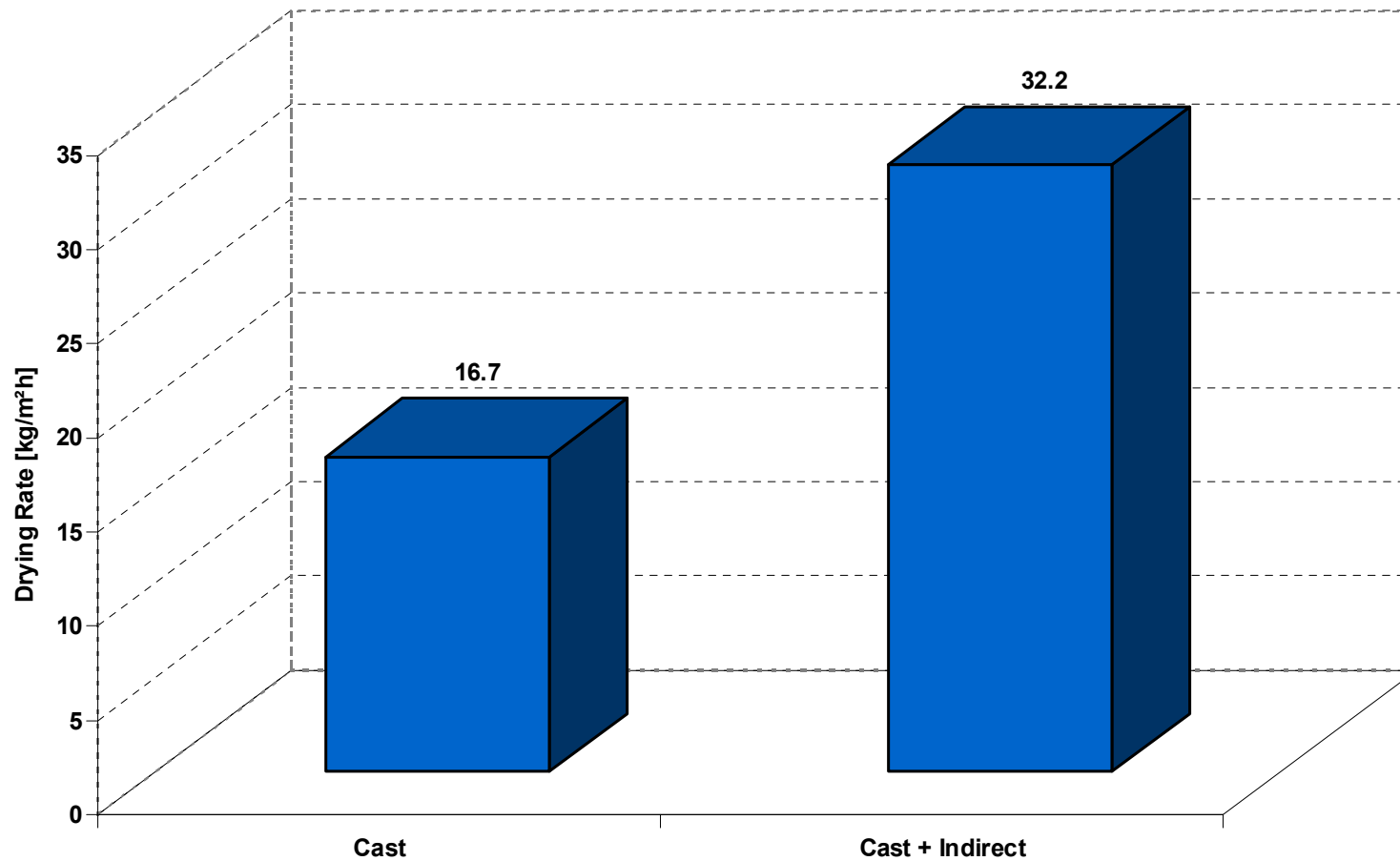

New technologies for drying sections

- Case study contact drying
 - Cast cylinder
 - Steel cylinder
 - High temperature cylinder
- Case study impingement drying
 - Indirect
 - Direct
 - Double sided
- Summary

Direct Impingement

Paper



Drying Fabric

Impingement direct

Layout drying section for simulation

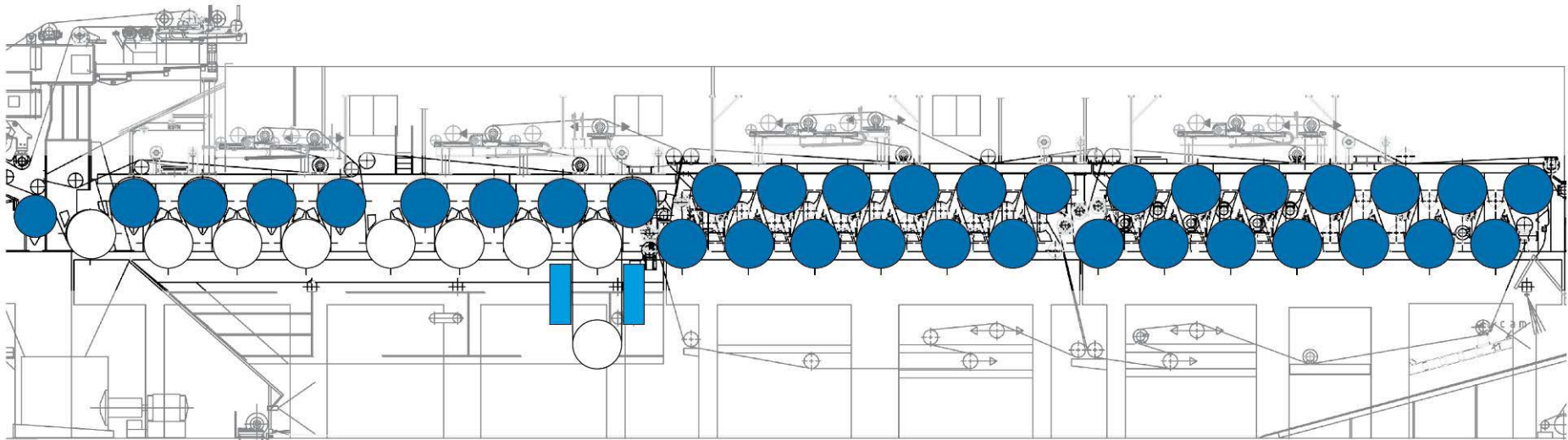

Impingement direct

Comparison sheet temperature vs. sheet dryness

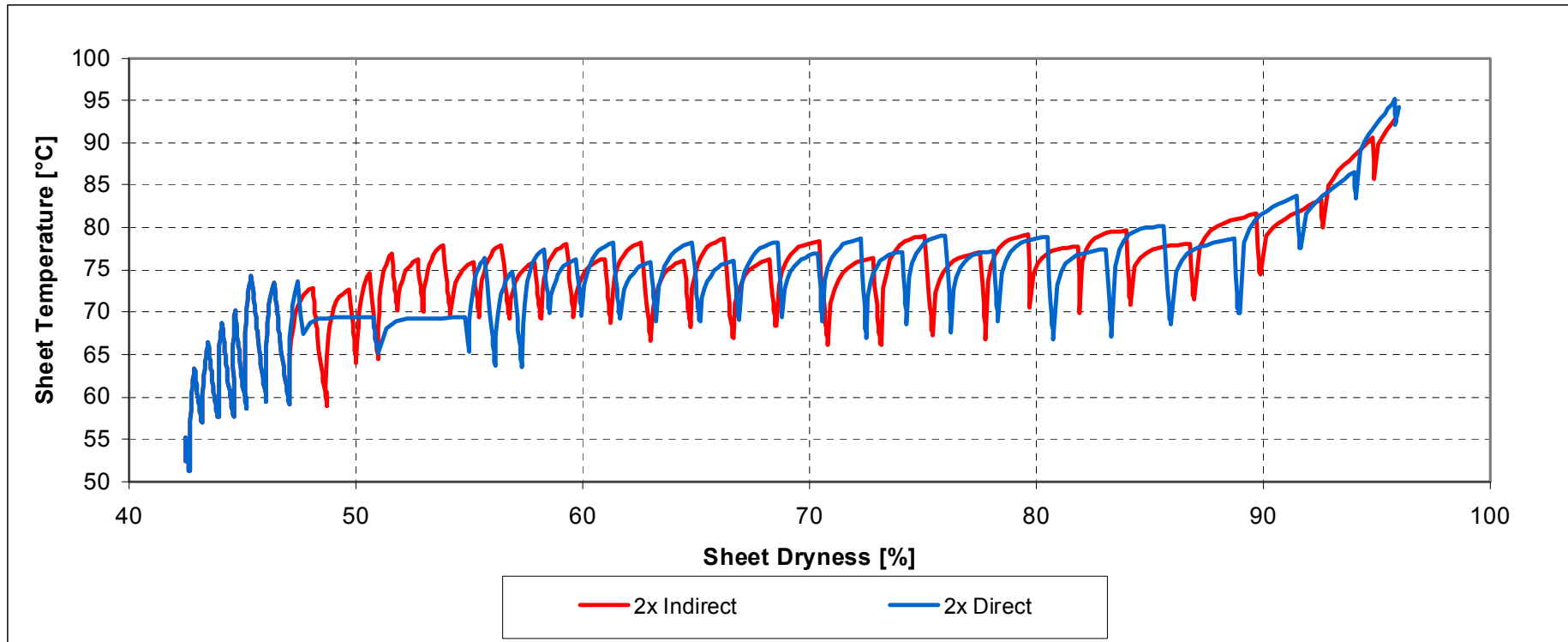

Comparison drying rates from simulation

Impingement direct

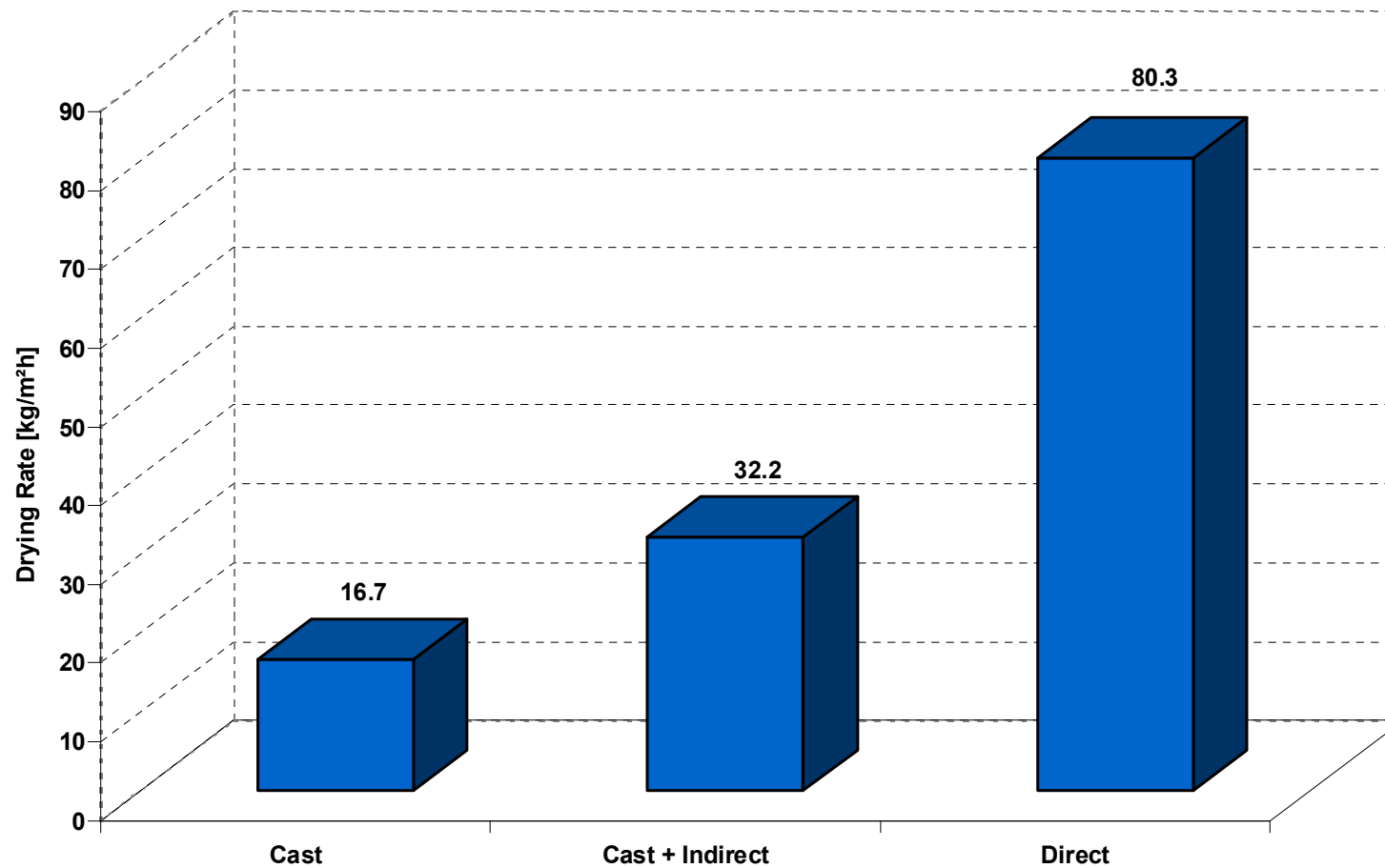

New technologies for drying sections

- Case study contact drying
 - Cast cylinder
 - Steel cylinder
 - High temperature cylinder
- Case study impingement drying
 - Indirect
 - Direct
 - Double sided
- Summary

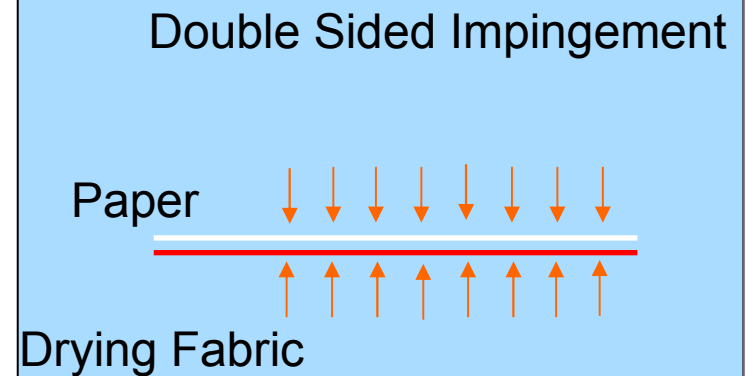

Impingement double sided

Test arrangement

Pilot machine

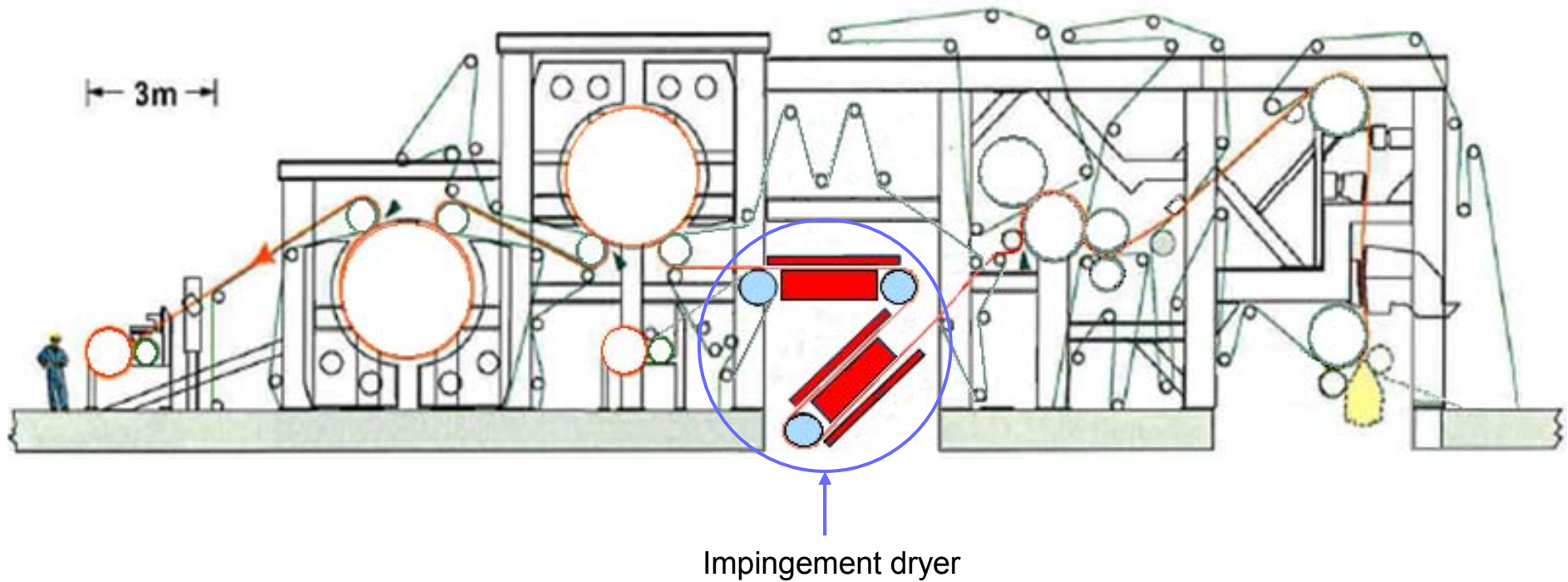

Impingement double sided

Results

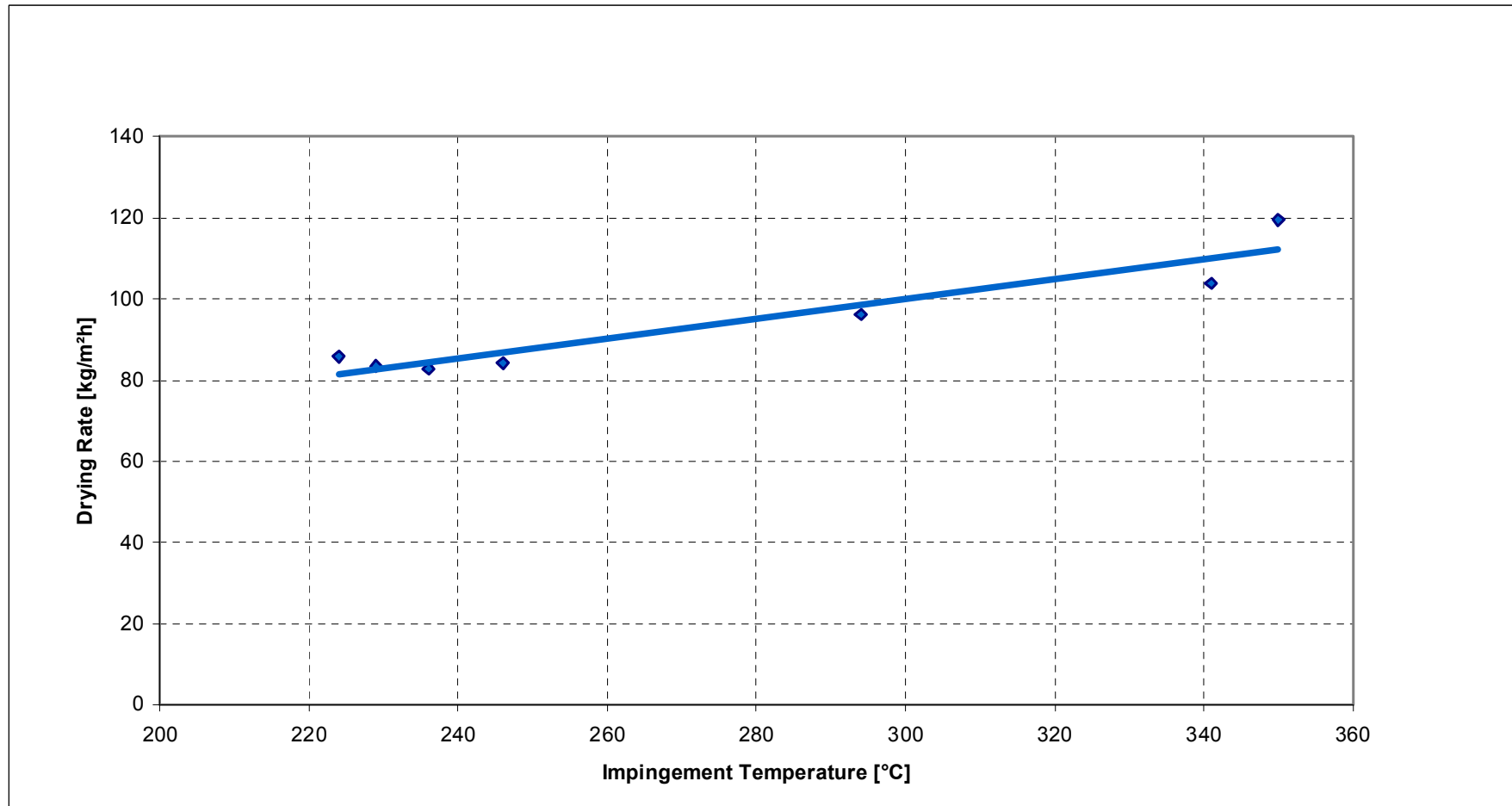

Impingement double sided

Layout drying section for simulation

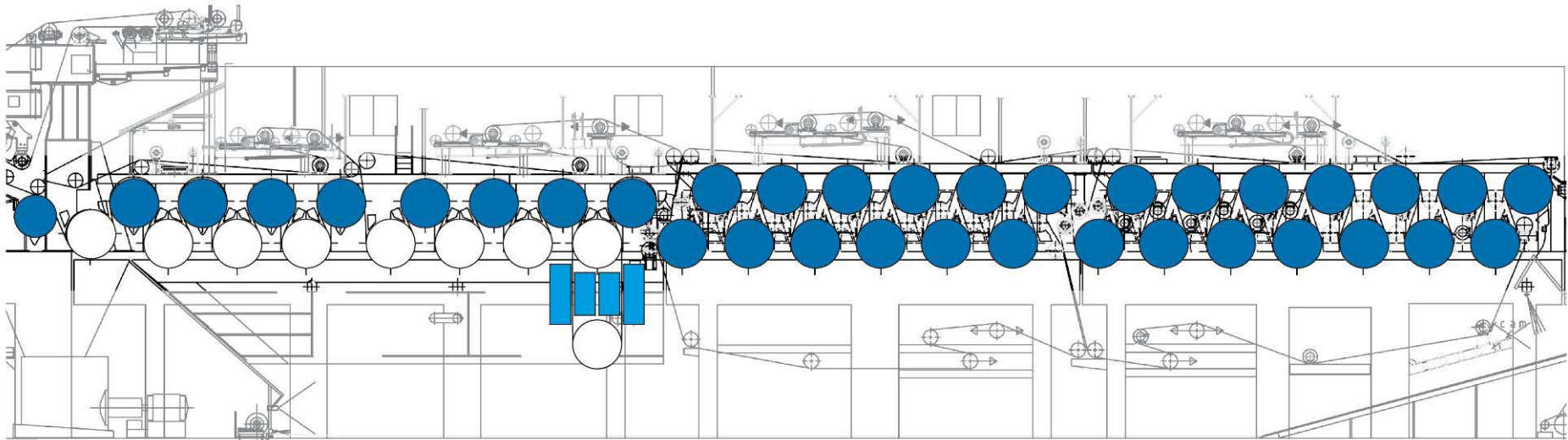

Impingement double sided

Comparison sheet dryness

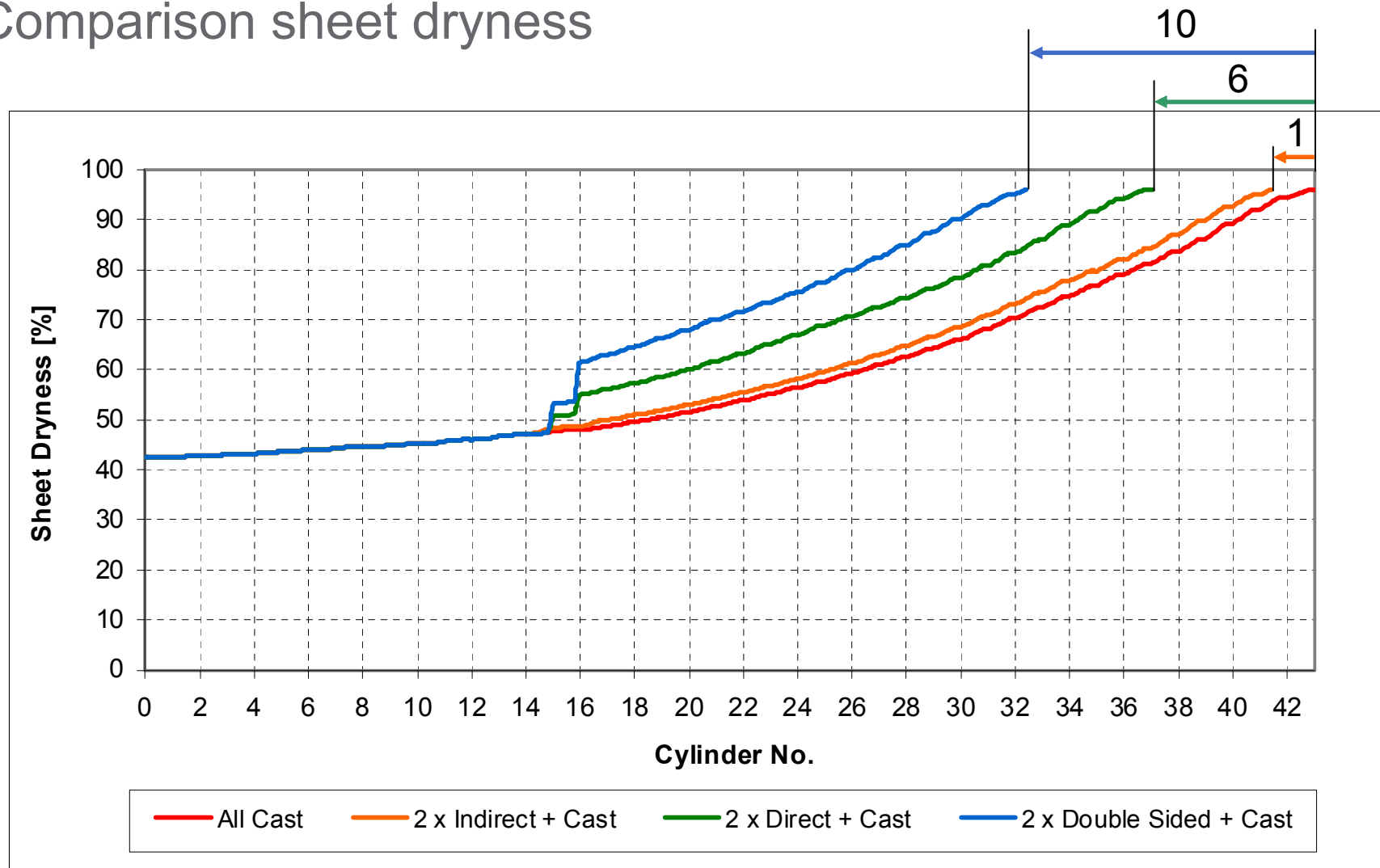

Impingement double sided

Comparison drying rates from simulation

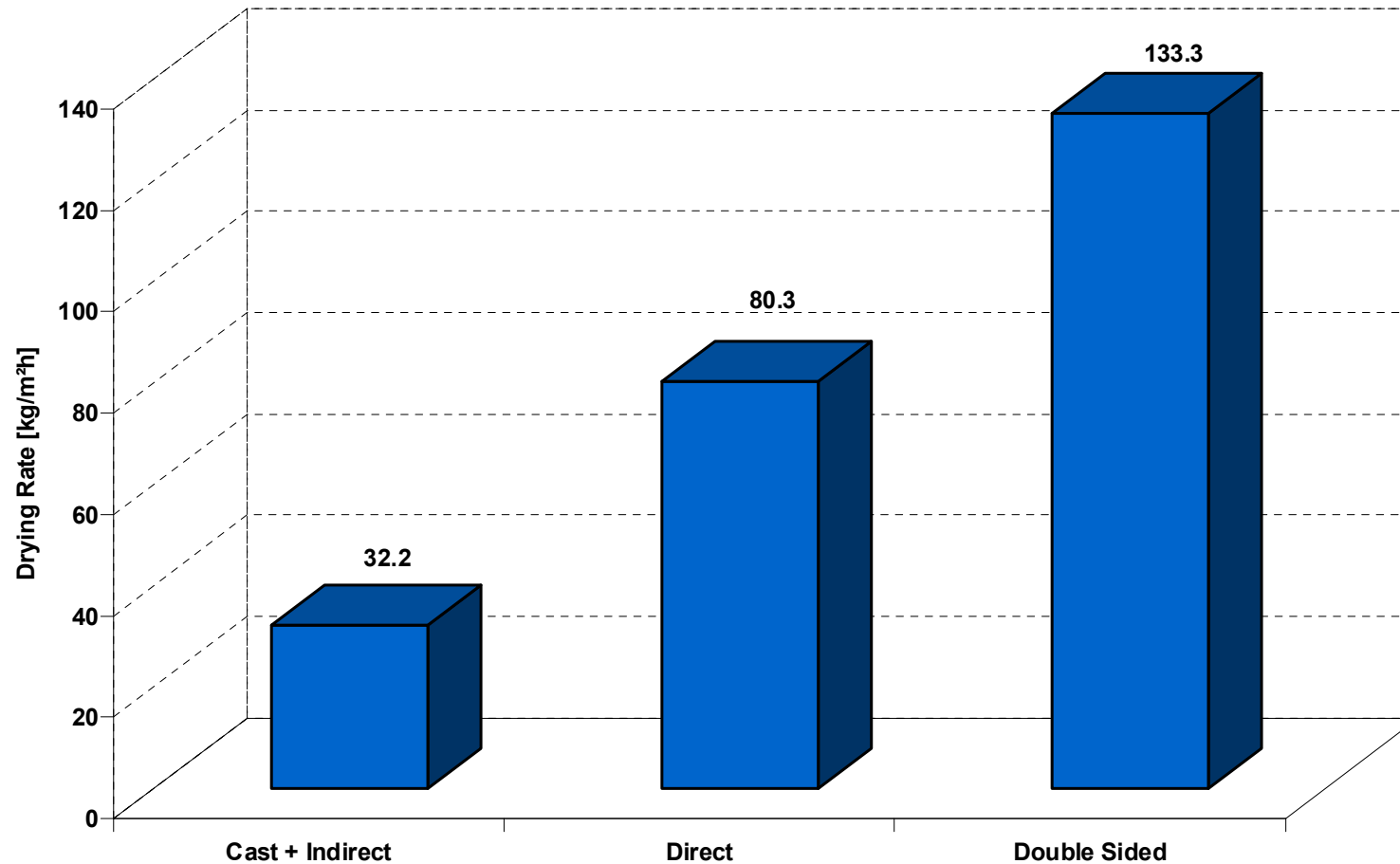

Sheet dryness

Different positions of double sided impingement

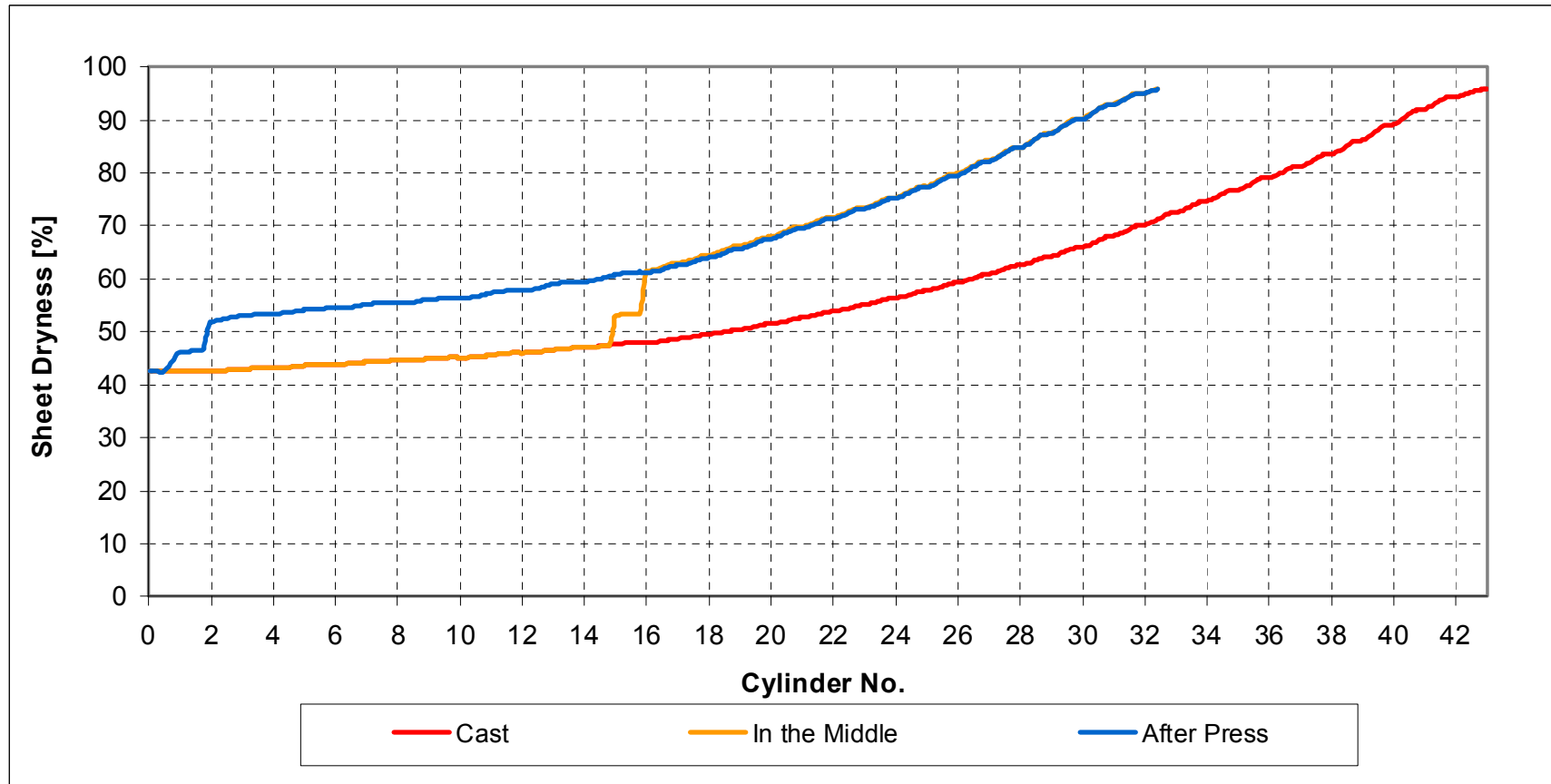

New technologies for drying sections

- Case study contact drying
 - Cast cylinder
 - Steel cylinder
 - High temperature cylinder
- Case study impingement drying
 - Indirect
 - Direct
 - Double sided
- Summary

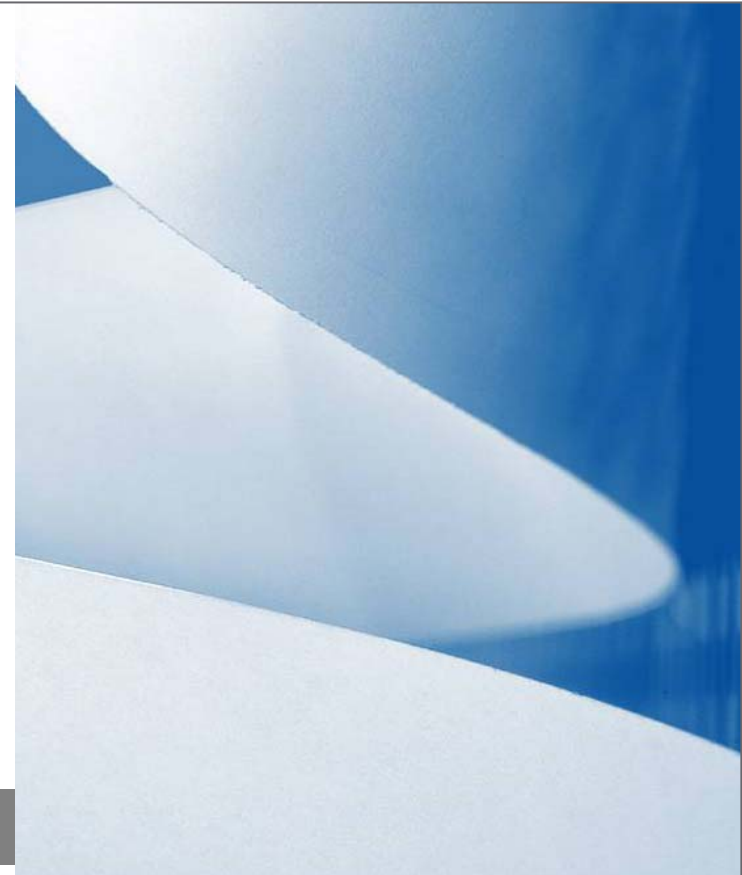

Comparison all drying rates from simulation

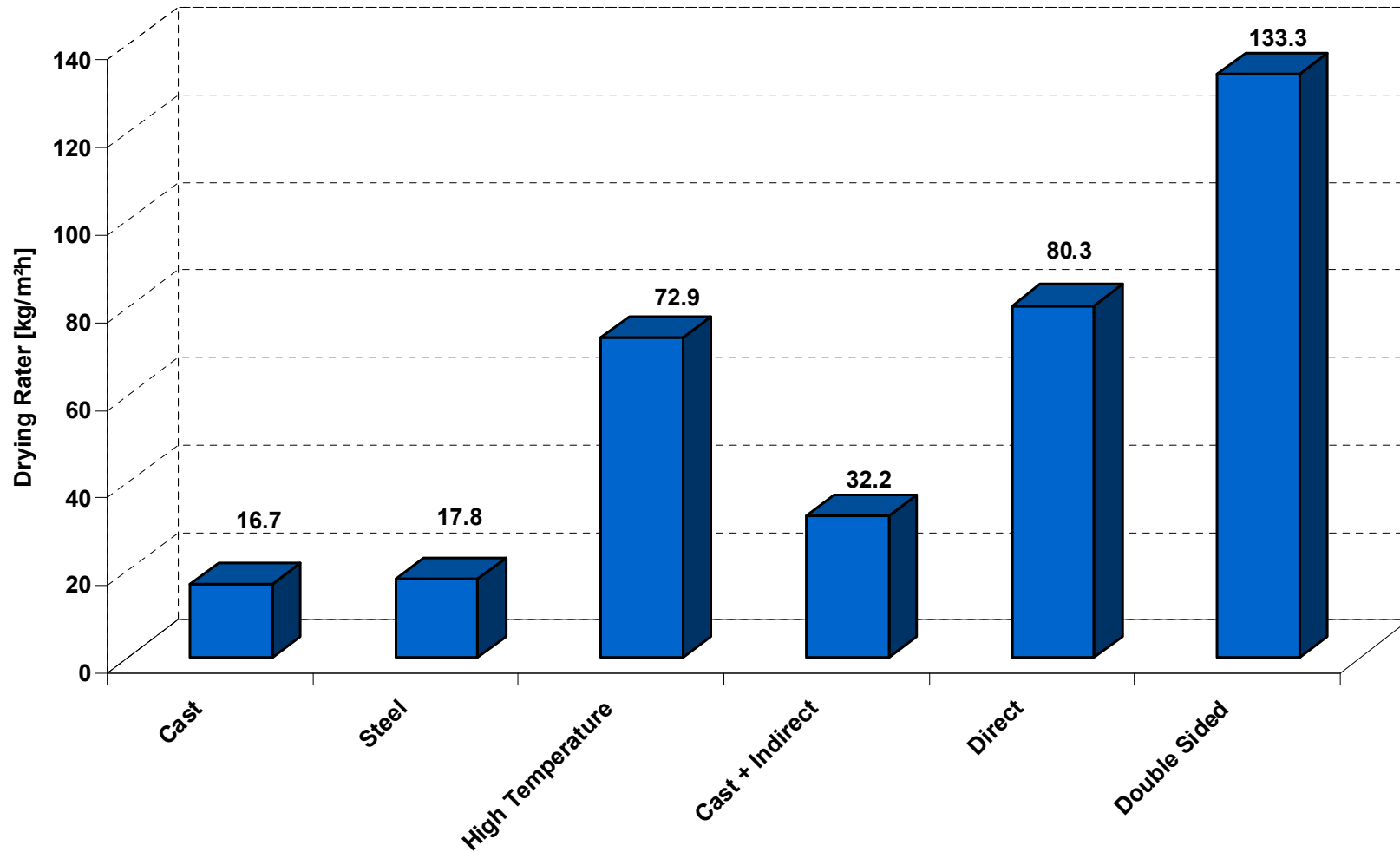



Legal Disclaimer

All data, information, statements, photographs, and graphic illustrations contained in this presentation are without any obligation to the publisher and raise no liabilities to ANDRITZ AG or any affiliated companies, nor shall the contents in this presentation form part of any sales contracts, which may be concluded between ANDRITZ GROUP companies and purchasers of equipment and/or systems referred to herein.

© ANDRITZ AG 2011. All rights reserved. No part of this copyrighted work may be reproduced, modified or distributed in any form or by any means, or stored in any database or retrieval system, without the prior written permission of ANDRITZ AG or its affiliates. Any such unauthorized use for any purpose is a violation of the relevant copyright laws.

ANDRITZ

Pulp & Paper

New technologies for drying sections

Comparison of different concepts

