



**THE CCIS's 2016
GOLDEN INNOVATION AWARDS**

Audacious, yet thoughtful.

Curious, yet prudent.

Progressive, yet realistic.

We are INNOVATORS.

Dear Ladies and Gentlemen, Entrepreneurs and Innovators,

The spirit of innovation has been recognised as a prime mover in attaining the strategic goals of enterprises and society in general, whereby it is becoming ever more obvious that it is actually you - the individuals - who are able to apply their knowledge in creating a competitive and innovative environment.

Slovenes have a great deal of the innate creative potential necessary for their successful development; however, this nation's innovative potential, is, unfortunately, far from fully exploited. If the appropriate conditions are provided, this entrepreneurial impetus, a precious source of new ideas and know-how, can be delivered by young people. Another important factor in any such delivery are the connections between research & development institutions and economic entities, as well as the transfer of innovations from mere research into entrepreneurial development and exploitation, which is the critical link in all successful knowledge- and innovation-based economies.

Markets are changing rapidly. Innovative companies embrace such changes as both an opportunity and a challenge, while simultaneously their innovative solutions to such challenges become the protagonist of further advancement.

Business processes need to adapt to the requisites of the market, whilst the relevance of innovation needs to be considered a principal value of all employees.

Within the scope of its programmes and measures, the state strives to promote innovation as a significant competence of both the individual and society as a whole, while research, development and innovation provide the basis for the future potentials of our economy.

I firmly believe that events such as Innovation Day, the Slovenian Innovation Forum and awards for this country's best innovations significantly contribute to raising awareness of Slovenian entrepreneurs, as well as the public at large, as to the importance of innovation in further development and prosperity.

My sincere congratulations to all award winners! I wish you every success in attaining your ambitious goals.

Miro Cerar, Prime Minister of the Republic of Slovenia

“Some men see things as they are and ask why? I dream of things that never were and ask why not?” quoted Robert Kennedy. An innovative approach results in something novel and different - new products, services, technologies and processes. Audacious, of course; but there’s no progress without audacity. Progress that the human race wants, if not needs. A man always strives towards that which he doesn’t have, those things that can make his life easier, more beautiful and better.

“The reasonable man adapts himself to the world; the unreasonable one persists in trying to adapt the world to himself. Therefore all progress depends on the unreasonable man,” claimed George Bernard Shaw.

How many such unreasonable people are there in Slovenia? People who ask themselves why not? People who trust in themselves, in their abilities and for whom failure isn’t something to cry about, but rather something to bring a smile to the face; people who know that motivation, perseverance, creativity, a desire to accomplish change and the seizing of opportunities will add up to success, if not today, then tomorrow.

I firmly believe that Slovenia is the land of innovators who enhance their spirit through creativity. In the past eight years, Slovenia has been the fourth fastest growing country on the Innovation Union Scorecard; it also ranks in the top-eighth of the most creative nations on earth, while as regards talent development it is ranked eighth among 139 countries.

But does this mean that we can stop and rest on our laurels? Absolutely not! If we are good today, we need to be better tomorrow so that we can remain competitive. Without innovation there is no progress, and this applies to the individual enterprise as well as society as a whole. This is why it is extremely important that Slovenes realise the significance of promoting the spirit, culture and climate of innovation. To this end, the Chamber of Commerce and Industry of Slovenia promotes and enhances the Innovative Slovenia brand that was developed several years ago. Innovative Slovenia provides comprehensive support to innovations, from concept through development and collaboration with partners, to promotion and placement in international markets. This is our contribution to the successful penetration of Slovenian innovations in foreign markets. And there are plenty of excellent innovations, testimony to which is attested by the awards granted each year to the very best. More than 7,000 Slovene innovators and over 2,200 innovations received an award - including 98 gold awards - over the past 13 years.

This year 768 innovators with 182 innovations filed applications. The 40 finalists selected for their audacity, success and competitiveness are today the candidates for the title of Slovenia’s best innovation.

Dear innovators, my sincere congratulations upon your awards! It is your hard work, engagement and creativity that contribute most to Slovenia’s visibility on the map of innovative nations. You and your achievements make us proud, and it is our fervent hope that there shall be plenty more in the future.

Marjan Mačkošek, President of the Chamber of Commerce and Industry of Slovenia

We proudly enter the second decade of two events dedicated to innovation – the **Slovenian Innovation Forum** and **Innovation Day**; both present an excellent opportunity for innovators to demonstrate their potentials as well as for Slovenia to present its capacities and capabilities.

With all certainty it can be stated that knowledge, entrepreneurship and the spirit of innovation are key drivers of future economic development. This has become particularly evident in the years following the global economic crisis; indeed, creativity is becoming ever more important in the modern organisation, and those enterprises which survive are innovation-oriented, competitive and closely follow market trends. Let's hope that the most difficult times have now passed and - on the basis of Slovenia's most recent positive economic indicators - that conditions are improving.

Innovation should not be considered mere technological progress because it has significantly larger dimensions fostered through the provision of appropriate conditions both within the company and its broader environment. It is, above all, a responsive and creative mentality which engenders new approaches in order to apply creative solutions, implement novelties as well as search for market niches.

The state, within the limits of its capacities, strives to fund innovation, research & development potential for the benefit of the economy as a whole. The goal of this country's **2014-2020 financial perspective** is the creation of an innovative, dynamic and open Slovenia. Increasing the **number of companies actively innovating** requires a combination of measures, to which end **276 million euros of European funds** are being made available for implementing the following measures:

- Principally, **support to research and innovation processes within enterprises** in order to increase value added and strengthen competitiveness on global markets.
- The co-funding of **strategic development innovation partnerships** in the priority domains of smart specialisation. By way of this, the links and networks already established within the adopted initiatives shall be supported and upgraded.
- Promoting the collaboration of Slovenian companies in international projects within the **EUREKA initiative**.
- Increasing innovation activity in small and medium-sized enterprises with the anticipation of introducing the **innovation voucher**.
- The provision of **refundable funds** for investments directly related to research and innovation processes, this in the event that analysis of financing gaps points to market failure in such areas.

These measures are complemented by others to enhance the competitiveness of small and medium-sized enterprises.

Planned instruments are aimed at attaining a **comprehensive and more focused approach** which includes the whole chain that translates the fruit of research into viable commercial products and thence economic growth. Only through the collaboration of enterprises with other institutions shall the implementation of new technologies, the nurture of innovation and the successful development and marketing of consequent new products provide a basis for the future success of the national economy as a whole. Indeed, this is what Slovenia needs most today.

Undoubtedly, the **Slovenian Innovation Forum** and **Innovation Day** are important stimulants in promoting the spirit of innovation, as well as a relevant factor in raising awareness as to its significance.

Dear innovators, I sincerely congratulate you on receipt of this year's awards, and, in all your future creative endeavours, may I wish you every success on the global market!

Zdravko Počivalšek, Minister of Economic Development and Technology

Dear Innovators,

Slovenes like to praise themselves as being an innovative nation, and our high-end innovations have made global breakthroughs in a number of fields. Indeed, by the end of the 19th century, Slovenian inventors became protagonists in the development of both the automobile and the aeroplane, and, in the modern era, we have excelled in such sectors as electronics and information technology.

Among 61 countries included in research into innovations in the EU, the International Institute for Management Development (IMD) ranked Slovenia 49th, which is six places ahead of last year. This progress is attributable to you all, innovative individuals and companies successfully competing on both local and global markets. Indicators now point to a recovery in global trade, and last year Slovenia was one of those EU states to record the greatest improvement to its economy.

For these reasons, we proudly and eagerly present Slovenian innovations at the annual national Innovation Forum. This year, we collaborated with the Chamber of Commerce and Industry of Slovenia in the selection of award winners, thereby joining two traditional selections for innovation awards at the national level. All 40 national award winners are presented at the fair which is a whole lot more than a mere exhibition of the best innovations. At the strategic level, it is a forum that brings together expert and general publics, the entrepreneur and the end user - consumer. Simultaneously it presents and explores important topical issues in the field of innovation, which encourage the Slovenian public to reflect on questions exerting a significant impact on the advancement of the innovative society as a whole. We strive to make visible the contribution of innovations to the progress and development of society as well as our own individual lives.

On behalf of SPIRIT Slovenia, may I take this opportunity to sincerely congratulate all national award winners on their innovations, and I eagerly hope that they shall continue to carry out their inspirational mission with enthusiasm in order that these essential values will be passed down to the next generation to further provide a basis for the future development of our innovative nation.

Gorazd Mihelič, Director of SPIRIT Slovenia, Public Agency

33rd

of 140 countries at innovations (World Competitiveness Report, WEF).

Indicator of economy's sophistication that explains a large part of business success.

14 places

up on ranking at productivity & efficiency (World Competitiveness Yearbook IMD).

Innovation output raises firm's key business parameters.

26th

of 109 countries (The Global Talent Competitiveness Index 2015-2016, Insead, Adecco) at appropriate environment for talent development.

Stimulative environment for development of employee's talents increases the firm's innovation capacity.

93% of EU-28 average

is the innovation relative performance (Innovation Union Scoreboard 2016, EC).

Slovenia is in the second group of countries – Strong Innovators which includes Member states Austria, Belgium, France, Ireland, Luxembourg, and UK. This implies stronger business results.

In upper eighth

of countries on creativity in economy (The Global Creativity Index 2015, Martin Prosperity Institute).

High ranking implies appropriate technology, values and human potential for development of creative industries.

Innovators' Thoughts

Thought as to how to be different must be ongoing.

The needs and expectancies of the market must be considered in the very concept of a product.

One has to anticipate the requirements of customers a few years ahead.

The ideas of developers must be co-ordinated with customer expectations and market trends.

Products must be original, eye-catching, of quality, as well as useful and sustainable.

What does it take to successfully market an innovation internationally?

Believe in your innovation.

Persistence is essential.

You need the right products at the right time in the right place.

Reliability is a good customer approach.

It takes insight into the target market, the customers and their needs.

An innovation requires appropriate product placement on the market, not merely placement.

Have faith in yourself and your product.

An innovation must surpass minimal standards.

Successful enterprises find a market niche which is not being exploited by others.

A company needs to constantly implement novelties in order to maintain the interest of the market.

Recipients of CCIS's 2016 Golden Innovation Awards

Company	Title of Innovation	
Adria Mobil, d.o.o.	Compact SLS – a New Compact Camper with Slide Out Technology	12
Akrapovič, d.d., PE Črnomelj	Akrapovič Titanium (R)Evolutionary Exhaust	14
BSH Hišni aparati d.o.o. Nazarje	MultiTalent 3 Food Processor	16
BSH Hišni aparati d.o.o. Nazarje	EQ.9 Fully Automatic Coffee Machine	18
Domel, d.o.o. in Nela razvojni center, d.o.o.	EC Motor with Integrated Electronics Option and up to 1 kW Power Output	20
ETI d.d. in RC eNeM d.o.o., Podružnica Keramični materiali in varovalke	NHXL 1500V D.C. gPV PV Fuse Link for Photovoltaic Systems	22
Gorenje, d.d., Velenje	Panasonic AutoCare Washing Machine	24
Hidria AET d.o.o.	Hidria AETERNUS - 2nd Generation Low-voltage Metallic Glow Plug	26
KRKA, d. d., Novo mesto	Delivery of Active Pharmaceutical Ingredients via Prolonged-Release Formulations in the Treatment of Schizophrenia and Bipolar Disorder	28
LEK farmacevtska družba d.d. Razvojni center Slovenija	Efficient and Sustainable Carbon-Carbon Cross-Coupling and its use in the Synthesis of Sitagliptin – Type 2 Diabetes Mellitus Drug	30
LEK farmacevtska družba d.d. Razvojni center Slovenija	Novel Approach for the Highly Efficient Production of Omeprazol	32
M Sora d.d.	Nature Optimo XLT Window	34
SIJ Acroni d.o.o.	Acid-Free Pickling of Hot and Cold Rolled Steel Strips	36
SwatyComet d.o.o., PE Zreče	Professional Range of Thin Cut-off Wheels for Stainless Steel	38

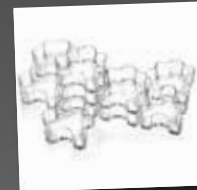
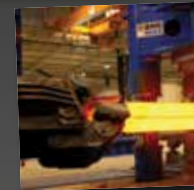
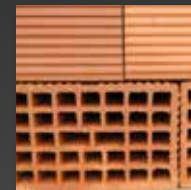
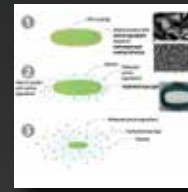
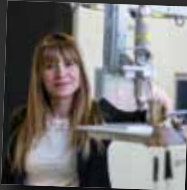

Innovation:**Compact SLS – a New Compact Camper with Slide Out Technology****Innovators:**

Anton Kastrevc, Uroš Dvornik, Matjaž Krajncič,
Miroslav Bobnar, Ivan Šegina, Matjaž Grm, MSc,
Mateja Kastrevc

Short Description:

Adria Mobil has developed its first camper with a slide-out rear wall. The living space remains unaltered and functional throughout the journey, and the wall is slid out only when the user desires the extra space. The innovation allows the immediate conversion of a lightweight, compact camper into a more spacious one.

Eminently suitable for driving in city centres, the Compact SLS Camper belongs to a group of small vehicles especially designed for the dynamic user.

Company:

Adria Mobil, d.o.o.
Straška cesta 50, SI-8000 Novo mesto, Slovenia
info@adria-mobil.si
www.adria-mobil.si



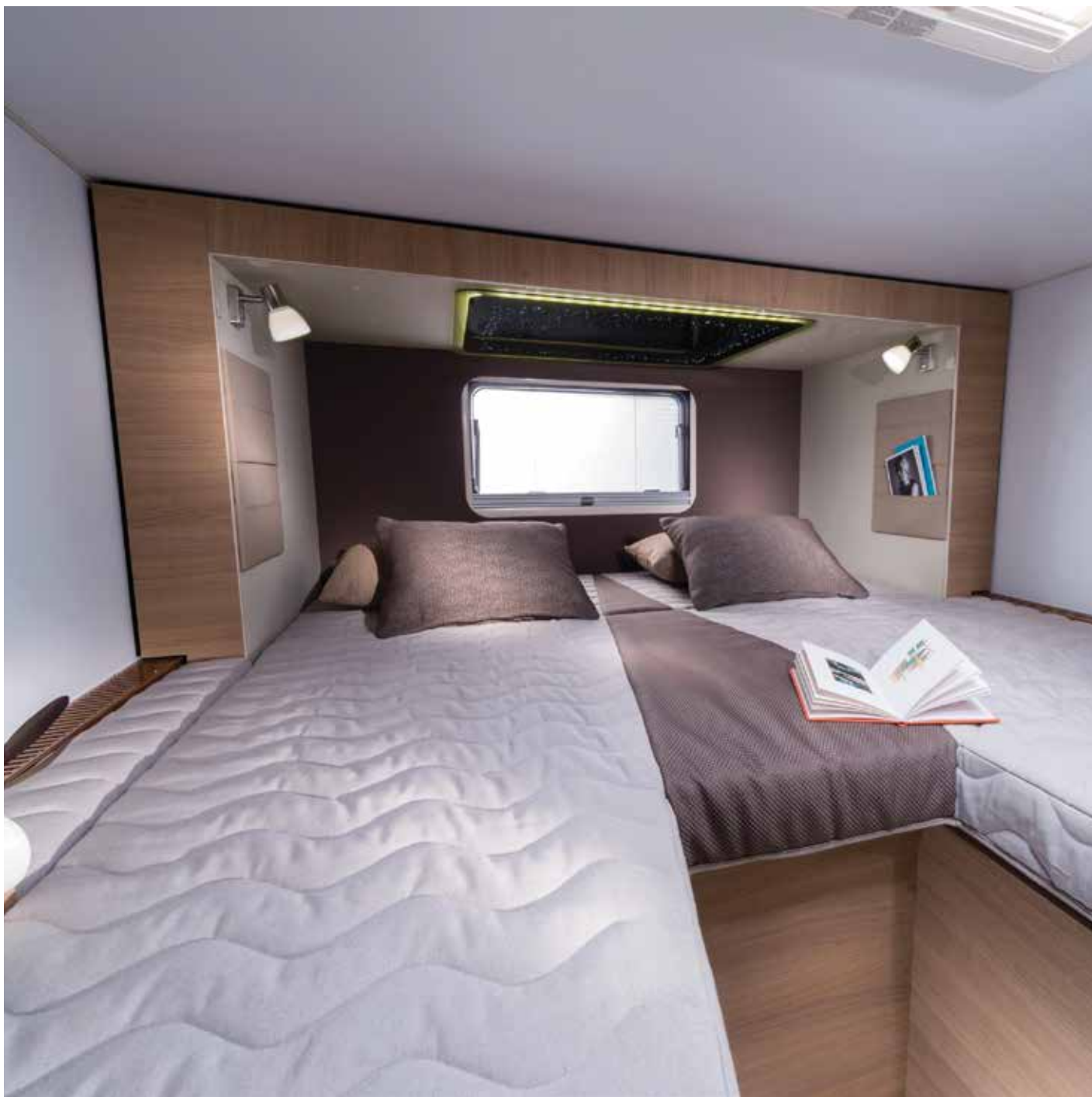

Innovation:**Akrapovič Titanium (R)Evolutionary Exhaust****Innovators:**

Igor Akrapovič, Tadej Zadel, Tomaž Ilovar, Marko Besal, Dragomir Stanković, Tjaša Makovec, Cveto Zupančič, Luka Sadar, Aleš Borin, Boštjan Veber, PhD

Short Description:

Akrapovič has enhanced its existing dynamic (r)evolutionary hexagonal exhaust in a new version constructed from high-grade titanium. Exquisitely finished with a handcrafted carbon-fibre heatshield and end-cap, the unique muffler is the latest compelling upgrade.

The use of titanium together with carbon composite components has reduced the overall weight of the product by a considerable 25.9%.

Company:

Akrapovič, d.d., PE Črnomelj
Ulica Heroja Stariha 24, SI-8340 Črnomelj, Slovenia
info@akrapovic.com
www.akrapovic.com





Innovation:**MultiTalent 3 Food Processor****Innovators:**

Jurij Pešec, Darko Rudež, Bogdan Kreča, Matej Berzelak, Dejan Gosar, David Potočnik, Boštjan Kovačec, Jože Skončnik, Marko Lenošek, Bojan Potočnik, Aleš Kreslin, Tadej Holcinger, Peter Leskovšek, Adam Koštomaj, Mirko Jurak, Tomo Iršič

Short Description:

The new compact and versatile kitchen assistant with more than 50 functions makes cooking and baking easier. The 800 W motor has 2 speed settings and a pulse function. The 2.3l transparent plastic mixing bowl can hold up to 500g flour + ingredients. Stainless steel discs can cut or grate fruit, vegetables and cheese thick or thin. The food processor can come with a chopper for fast and precise processing of herbs, nuts, onions or garlic, and a grinder for processing hard ingredients such as coffee beans, hard cheese, grains, spices or ice cubes. The space saving design SmartStorage offers the storage of standard accessories directly in the bowl, and there is also the integrated cable storage.

Company:

BSH Hišni aparati d.o.o. Nazarje
Savinjska cesta 30, SI-3331 Nazarje, Slovenia
+386 3 83 98 222 (Nazarje)
+386 1 58 30 850 (Ljubljana)
www.bsh-group.com/laender/si

B/S/H/

BSH Hišni aparati d.o.o. Nazarje





Innovation:**EQ.9 Fully Automatic Coffee Machine****Innovators:**

Matjaž Filo, Igor Žibret, Matjaž Uršej, Peter Miklavc, Evgen Kozelj, Klemen Britovšek, Klemen Lončarič, Tadej Jeraj, Aleš Kreslin, Jan Ažman

Short Description:

Integrated into a body made from brushed stainless steel equipped with a large color display, the EQ.9 fully automatic coffee machine is the new flagship of the EQ family and provides even more flexibility for individual preferences with its modern design. The intuitive menu navigation makes selecting programmes easy with the rotating button. One cup or even two of your favourite coffee can be prepared with only a touch of a button (oneTouch DoubleCup). The milk system with fully automatic steam cleaner (autoMilk Clean), the dualBean system with two separate grinding units and bean containers and the baristaMode for precise setting of a fine aroma are all new features. Users can even save their own coffee settings and recall them easily by pushing a single button. It's one of the quietest fully automatic coffee machines.

Company:

BSH Hišni aparati d.o.o. Nazarje
Savinjska cesta 30, SI-3331 Nazarje, Slovenia
+386 3 83 98 222 (Nazarje)
+386 1 58 30 850 (Ljubljana)
www.bsh-group.com/laender/si

B/S/H/

BSH Hišni aparati d.o.o. Nazarje





Innovation:**EC Motor with Integrated Electronics Option and up to 1 kW Power Output****Innovators:**

Sandi Dolenc, Bojan Bertoncej, Bojan Krmelj, Mitja Grohar, Blaž Rihtaršič, Dejan Flander, Matej Tadina, Matjaž Kokalj, Jure Pfajfar, Igor Demšar, Klemen Eržen, Boris Benedičič, Jan Koblar, Nejc Černilogar, Franci Mohorič, Irena Megušar, Tomaž Trpin, Matevž Rihtaršič, Irena Bertoncej, Aleš Levanič, Milan Vizjak, Nataša Dolenc

Short Description:

EC motors and drives have gone through intensive development over the recent years. Due to the possibility of improving energy and material efficiency, they have become a trend.

New Domel universal EC motor, which has been developed in cooperation with Development Centre NELA, represent state of the art design solutions, which are result of various competencies, particularly long-term experience in overmolding. This gives the motor a competitive advantage on a wide scope of applications, such as home appliances, ventilation, pumps and other areas with continuous mode of operation.

Company:

Domel, d.o.o.
Otoki 21, SI-4228 Železniki, Slovenia
info@domel.com
www.domel.com

Nela razvojni center, d.o.o., Subsidiary OTOKI
Otoki 21, SI-4228 Železniki, Slovenia
info@nela.si
www.nela.si

DOMEL

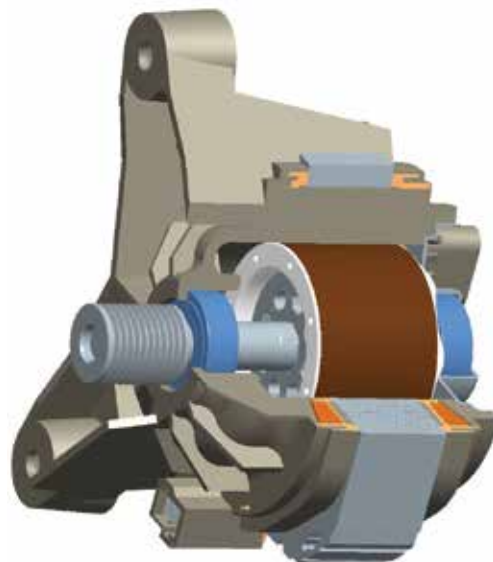



Innovation:**NHXL 1500V D.C. gPV PV Fuse Link for Photovoltaic Systems****Innovators:**

Brane Lebar, Viktor Martinčič, Anton Rome, Urban Kos

Short Description:

These fuses protect electrical installations and photovoltaic cells against reverse electrical current. The NV gPV fuse links are crucial safety components, directly affecting the security of the entire PV system as well as ensuring fire protection in the event of overcurrent. These high-quality fuse links operate at higher voltages, enabling a 15% increase in efficiency as well as lower cabling costs; they also reduce the necessary investment in PV power plants by 30%.

Company:

ETI d.d. in RC eNeM d.o.o., Subsidiary Ceramic Materials and Fuses

Obrezija 5, SI-1411 Izlake, Slovenia

eti@eti.si

www.etigroup.eu





Innovation:**Panasonic AutoCare Washing Machine****Innovators:**

Boštjan Sovič, MSc, Robi Pogorevc, Jakob Koželjnik
Lovro Krajnc, Matjaž Kuhar, Marko Pečnik, Niko Dren,
Zlatko Novak, Uroš Koren, Urh Sredenšek, Uroš Trupej,
Sandi Vitanc, Rok Lah, Duško Skarlovnik, Klemen Horvat,
Takayuki Ishihara, Masahiro Itami, Akira Shoji, Go Ito,
Arata Takahashi, Tomotaka Yagi, Yuko Minayoshi,
Takeo Matsuki, Hideaki Ushijima, Masanao Segawa

Short Description:

One of the first larger common projects since Gorenje and Panasonic announced strategic alliance, was the development of a new generation of washing machines. Combining R&D knowledge and taking the advantage of other synergies, both companies have recently developed washing machines with 8 kg and 10 kg load for the brand Panasonic. These newly developed appliances boast a range of advanced functions, such as automatic washing program Autocare. The use of steam during washing helps to reduce wrinkles in fabric and effectively removes allergens. The appliances have exceptional energy efficiency A+++ -40% and operate extremely quietly.

Company:

Gorenje, d.d., Velenje
Partizanska 12, SI-3320 Velenje, Slovenia
info@gorenje.com
www.gorenje.com

gorenjegroup





Innovation:**Hidria AETERNUS - 2nd Generation Low-voltage Metallic Glow Plug****Innovators:**

Tomaž Mrak, Dušan Kuštrin, Andrej Kragelj, Gregor Kuštrin, Mitja Čebokli, Peter Tonkli, Stojana Vesković

Short Description:

The solution represents a quantum leap in European diesel engine start technology. The numerous innovations integrated into the product include new welding technology solution which extends the glow plug's durability by more than 20%. The start phase of the diesel engine is also optimized resulting in a reduction of CO₂, NO_x and particulate emissions, thus making the modern diesel car cleaner.

The company has already signed a contract for supplying this new solution to one of Europe's largest vehicle manufacturer.

Company:

Hidria AET d.o.o.
Poljubinj 89A, SI-5220 Tolmin, Slovenia
info@hidria.com
www.hidria.com





Innovation:**Delivery of Active Pharmaceutical Ingredients via Prolonged-Release Formulations in the Treatment of Schizophrenia and Bipolar Disorder****Innovators:**

Irena Bobnar, MSc, Polona Bukovec, PhD, Andrej Gartner, Iztok Klobčar, Simon Kukec, PhD, Roman Lenaršič, PhD, Gregor Ritlop, Janika Slanc Vovk, MSc, Elena Smirnova, PhD, Jernej Zadnik, PhD

Short Description:

The company developed an innovative generic pharmaceutical product in the form of prolonged-release film-coated tablets (in the form of hemifumarate salt) that ensures appropriate kinetics of API release and thus safe and effective treatment of patients with schizophrenia and bipolar disorder. With these innovative solutions in the entire process of implementing the innovation from the API, pharmaceutical dosage form and evaluation methods to confirming comparability with the reference medicine, solutions have been provided in the company which ensure successful marketing of the product in the key markets.

Company:

KRKA, d. d., Novo mesto
Šmarješka cesta 6, SI-8501 Novo mesto, Slovenia
info@krka.biz
www.krka.si



1

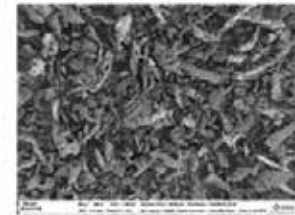
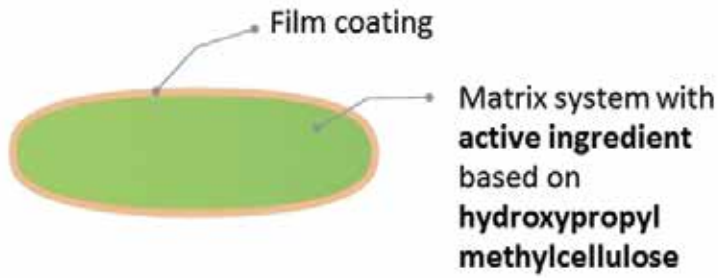

2

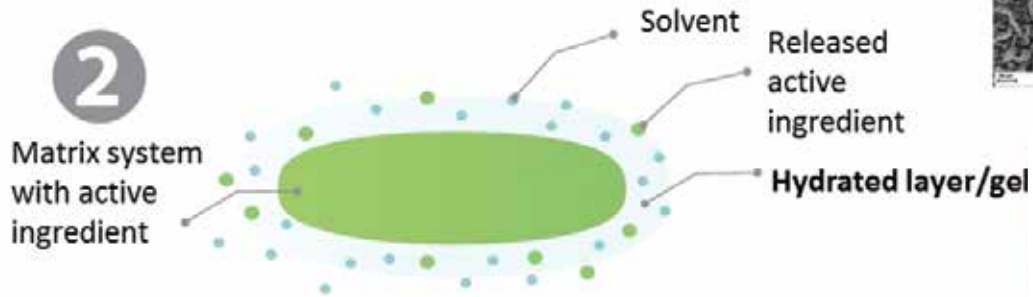

3

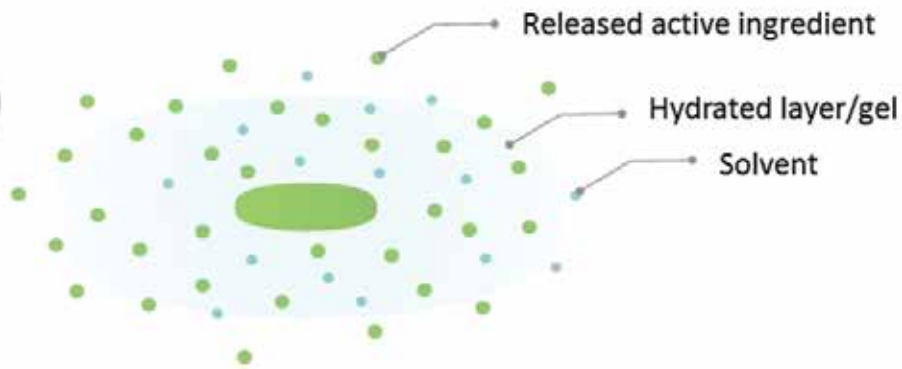

Innovation:**Efficient and Sustainable Carbon-Carbon Cross-Coupling and its use in the Synthesis of Sitagliptin – Type 2 Diabetes Mellitus Drug****Innovators:**

Lek farmacevtska družba d.d.:

Zdenko Časar, PhD, Gaj Stavber, PhD

Faculty of Pharmacy, University of Ljubljana:

Matej Sova, PhD, Rok Frlan, PhD, Stanislav Gobec, PhD

Short Description:

The company has developed a new method for the formation of carbon-carbon bonds, and a solution which introduces the use of “green” catalytic processes. In addition, Lek’s independent synthesis of generic active ingredients facilitates the provision of high-quality medicines - including Sitagliptin - at a significantly lower price.

Company:

LEK farmacevtska družba d.d.

Development Center Slovenia

Verovškova 57, SI1527 Ljubljana, Slovenia

info.lek@sandoz.com

www.lek.si



član skupine Sandoz
a Sandoz company

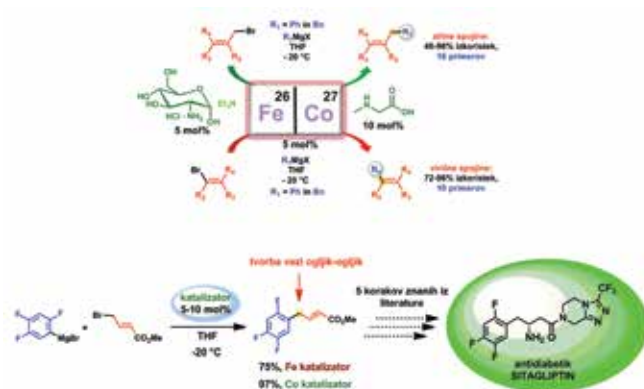

Sarcosine based Co catalyst:

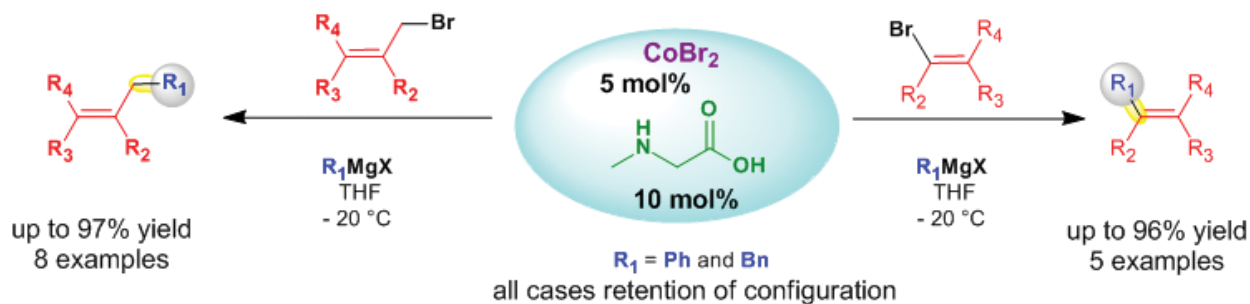

D-(+)-Glucosamine hydrochloride based Fe catalyst:

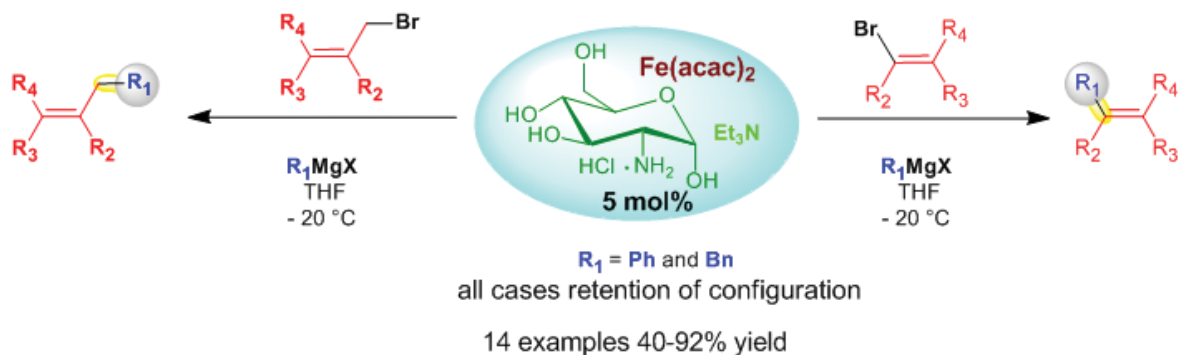

Sitagliptin case:

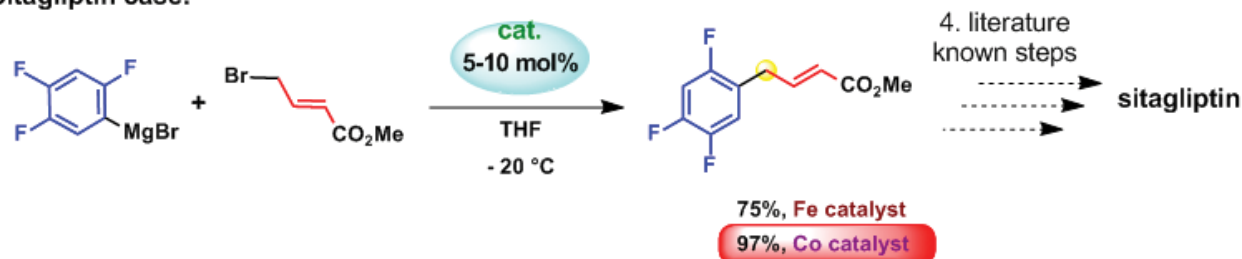

Innovation:**Novel Approach for the Highly Efficient Production of Omeprazol****Innovators:**

Rok Starič, Petra Perhavec, Jernej Grmaš, Jerneja Opara, PhD, Mateja Novak Štagoj, PhD, Klara Megušar, Dušan Gašperlin, Franci Sopotnik

Short Description:

The main advantages of this new process for manufacturing the drug Omeprazol are an extremely reduced manufacturing time, elimination of the use of acetone, reduction in the quantities of ethanol needed, as well as lower water and energy consumption. As a result, high-quality, safe, effective and more affordable medicines will be entering the market.

Company:

LEK farmacevtska družba d.d.
Development Center Slovenia
Verovškova 57, SI1527 Ljubljana, Slovenia
info.lek@sandoz.com
www.lek.si



član skupine Sandoz
a Sandoz company

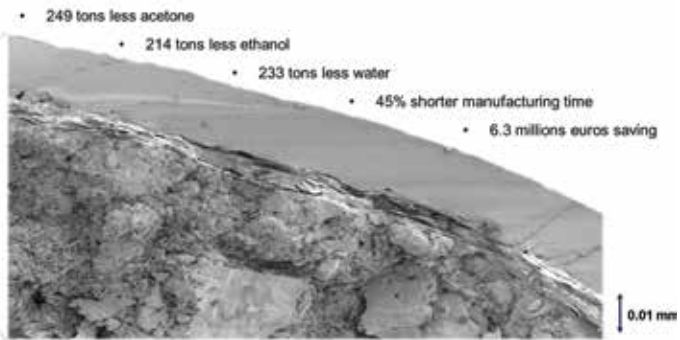
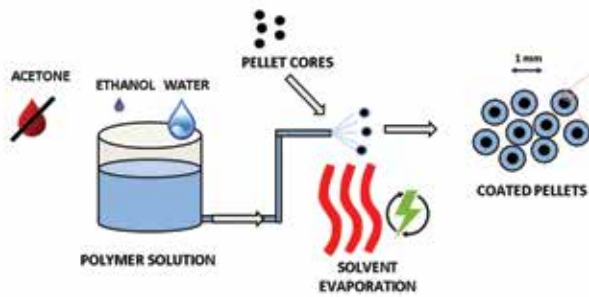

* Effect on year scale

Innovation:**Nature Optimo XLT Window****Innovators:**

M Sora joinery

Short Description:

M Sora has developed a passive window made entirely from special spruce of Slovenian origin. Its structure and properties are created through a patented procedure of thermal modification which has been developed by the Slovenian company Silvaprodukt d.o.o. and the Biotechnical Faculty of Ljubljana University.

The new window exhibits excellent thermal properties, higher durability and dimensional stability than conventional windows made from spruce wood, whereas window profiles have the appearance of tropical wood.

Company:

M Sora d.d.

Trg svobode 2, SI-4226 Žiri, Slovenia

okna@m-sora.si

www.m-sora.si

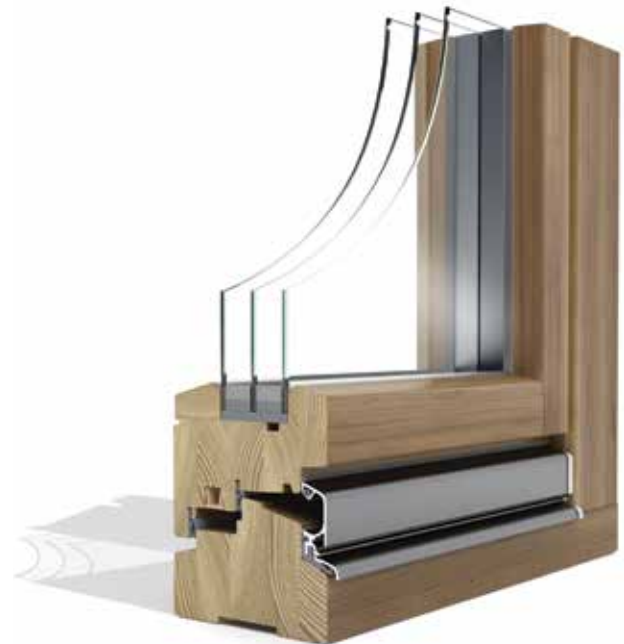



Innovation:**Acid-Free Pickling of Hot and Cold Rolled Steel Strips****Innovators:**

Janez Katnik, Bojan Finc

Short Description:

This non-acidic method is a new innovative technology for cleaning metal strips. The combination of a sandblasting machine and position of sandblasting turbines, together with the selection of the abrasive material and brushing technology, make this process unique. This innovation replaces final grinding process of steel strips, which also yields high economic benefits.

As this new technology does not use chemicals, it is both cheaper and more environmentally friendly.

Company:

SIJ Acroni d.o.o.

Cesta Borisa Kidriča 44, SI-4270 Jesenice, Slovenia

info@acroni.si

www.acroni.si





Innovation:**Professional Range of Thin Cut-off Wheels for Stainless Steel****Innovators:**

Valentina Prapotnik, Franja Juhart, Milena Krajnik,
Marija Kotnik, Valerija Napotnik

Short Description:

This innovative range of thin cutting wheels replaces the previous standard line. Advantages over the standard line include a most excellent and faster cutting ability, durability, and up to 20% more cuts per disc. Despite this improvement in efficiency and properties, including with the ability to cut all types of steel, production costs have not risen.

Company:

SwatyComet d.o.o., PE Zreče
Tovarniška cesta 5, SI-3214 Zreče, Slovenia
info@swatycomet.si
www.swatycomet.si





Other recipients of CCIS's 2016 Innovation Awards

Receipients of silver innovation awards		
Bijol d.o.o., Vuzenica	www.bijol.si	BIJOL BWS160 Forestry Skidder
Bosio, d.o.o.	www.bosio.si	BOSIO MAN14/8 Manipulator
ETI d.d. Izlake in NELA RC d.o.o.	www.etigroup.eu	KZS-EDI Residual Current Operated Circuit Breaker with Overcurrent Protection
Farma GRS, d.o.o.	www.farma-grs.si	New Synthesis Path and Crystalline Forms of Macrolide API in the Treatment of Respiratory Infections in Veterinary Medicine
Hidria TC Tehnološki center d.o.o.	si.hidria.com/si/o-nas/innovativni-center/tehnoloski-center	Ultrasonic Chrome Welding Machine for Porsche Panamera Side-Panel Strips
Hyb, d.o.o. in IN. Medica	www.hyb.si	The FreeHand System
Johnson Controls Slovenj Gradec d.o.o., Slovenj Gradec	www.johnson.com	Assembly and Control Line for Headrests, Center Consoles and Side Padding for the Volvo V54x
Kolektor Group d.o.o.	www.kolektor.com	Environmentally Friendly and Economical Plasma Spray Coating Process in the Production of Components for the Electro and Automotive Sectors
Kreativni aluminij, d.o.o. in VIP Virant, d.o.o.	www.kreal.si www.vip-virant.si	Lumenova CCL06 - LED Reflector Optics Lamp for Street Lighting
Ledinek engineering, d.o.o.	www.ledinek.com	Multiplan Four-side Planer and Moulder with Ledinek Tool Management System
Lek Veterina, d.o.o.	www.lek-veterina.si	Premix Method Using Thermo Stable Vitamin C in the Production of Anti-stress Feed for Laying Hens
Mahle Letrika d.o.o.	www.letrika.mahle.com	Heavy Duty Solenoid for Starter Motors with Pull Force Control
Meltum, logistika in transport d.o.o.	www.meltum.si	Isocentric Skis
SIJ Metal Ravne d.o.o., Ravne na Koroškem	www.metalravne.com	Forging and Heat Treatment in Precipitation Hardening Stainless Steels of Larger Dimensions
Primat, d.d.	www.primat.si	New Generation of Explosion Resistant ATM Safes

Reipients of silver innovation awards

Sastela d.o.o. in Engrotuš d.o.o.	www.sastela.si www.tus.si	Slovenske Dobrote Potica
Silco d.o.o.	www.silco-automotive.com	Automotive Refinishing Without Base Coat Hardener
Steklarna Hrastnik d.o.o.	www.hrastnik1860.com	Puzzle Bowls – Connection Experiences
Tehnos d.o.o.	www.tehnos.si	MPS 150 Asparagus Fern Cutter
TPV d.o.o.	www.tpv.si	Thin Walled Oil Deflector with Increased Infinite Fatigue Strength
Varstveno delovni center Zagorje ob Savi	www.vdc-zagorje.si	European Voluntary Service (EVS) for a Higher Quality of Life in the Zagorje ob Savi Occupational Activity Centre

Reipients of bronze innovation awards

Dukin, razvoj ekološke opreme d.o.o.	www.dukin.si	StyleOUT Waste Enclosure System – Above-ground waste bin storage
INO Brežice d.o.o.	www.inobrezice.si	BOXER Flail Mower
Luka Koper d.d.	www.luka-kp.si	Marine Sediment Bricks
Petrol energetika d.o.o. in SIJ Metal Ravne d.o.o., Ravne na Koroškem	www.petrol.si www.metalravne.com	Utilisation of Waste Heat from a Metallurgical Plant in District and Domestic Hot Water Heating
Kovis d.o.o.	www.kovis-group.si	K25L Axle Box with Adhered Wear Plates

Chamber of Commerce and Industry of Slovenia Innovation Awards

The CCIS Innovation Awards have a long tradition, and this year we celebrate the 20th edition. New innovative and improved products and production technologies are awarded, as are innovations pertaining to organisation, service provision and marketing.

This year, the Awards are granted in cooperation with the Ministry of Economic Development and Technology and SPIRIT Slovenia, Public Agency.

Selection of the CCIS Innovation Award winners is a two-step process. Firstly, the regional chambers invite entries from local innovators, and their projects and innovations are assessed according to a set of criteria which are applied both regionally and thence nationally. All innovations that meet the application criteria are considered, whilst the best within the individual competitions receive gold, silver and bronze awards.

The outstanding innovations from Slovenia's thirteen regions are then considered and judged in the context of a national competition for the country's best innovation, at which it is far from easy to attain a golden award. All entries must meet three main criteria pertaining to originality, viability and contribution to the clean environment as well as six sub-criteria.

The innovation:

- has to be original, new or significantly better from that which is currently available on the market.
- must be attributable and, accordingly, adequately protected (e.g. under a patent, brand, trademark or secret know-how).
- should be commercially viable and thus capable of enjoying market success (i.e. recognised by customers, consumers or users).
- promotes or upgrades the innovation culture in the participating organisation and makes a positive economic or social contribution locally, regionally, nationally or internationally.
- is a positive development in the context of environmental issues.

The innovations presented in this catalogue made it through two selections as well as fulfilled all of the abovementioned criteria, hence they are considered fully deserving of the 2016 Slovenian National Innovation Awards.

We congratulate all award winners

The CCIS's 2016 Golden Innovation Awards

Published by: Chamber of Commerce and Industry of Slovenia

Project manager: Simona Rataj, MSc.

Ljubljana, September 2016



HOTTEST INNOVATIONS